

**The Ari (1,644 sq ft) – Front**

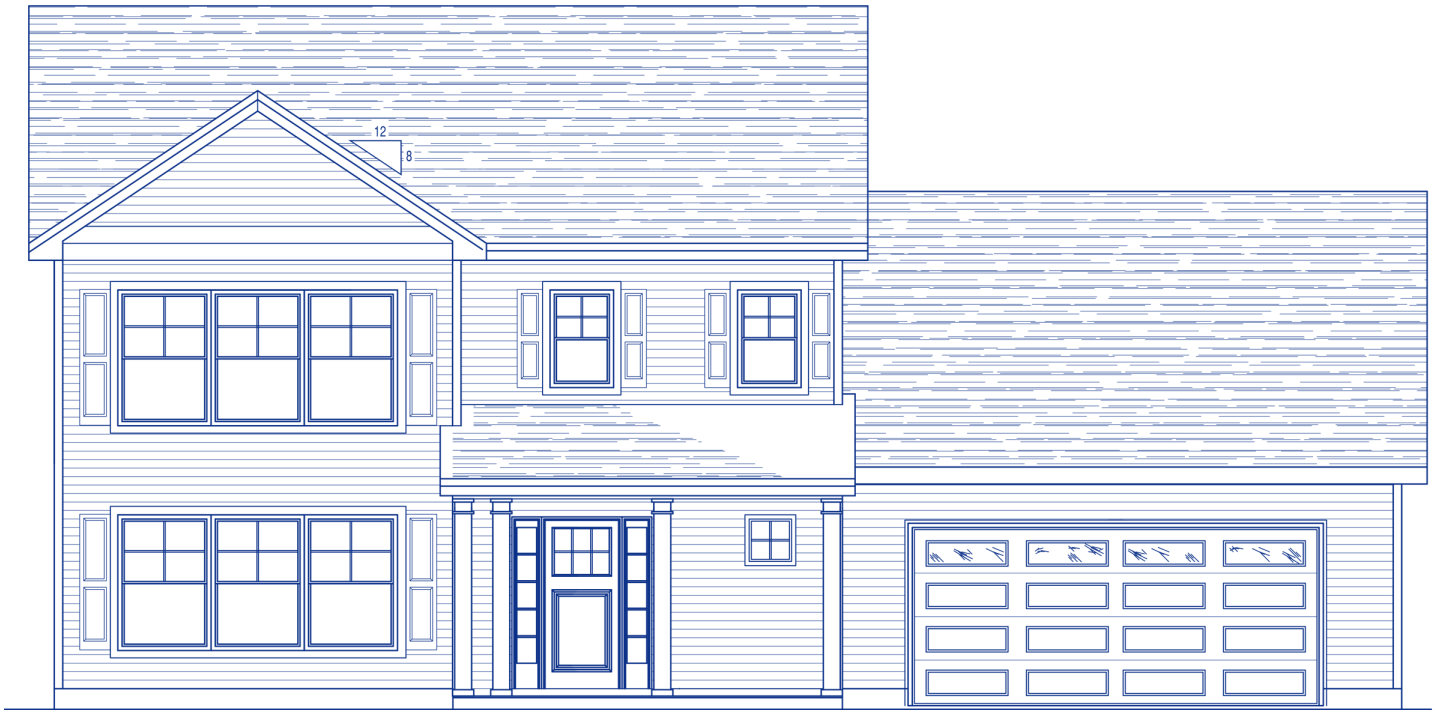

**The Ari – Rear**

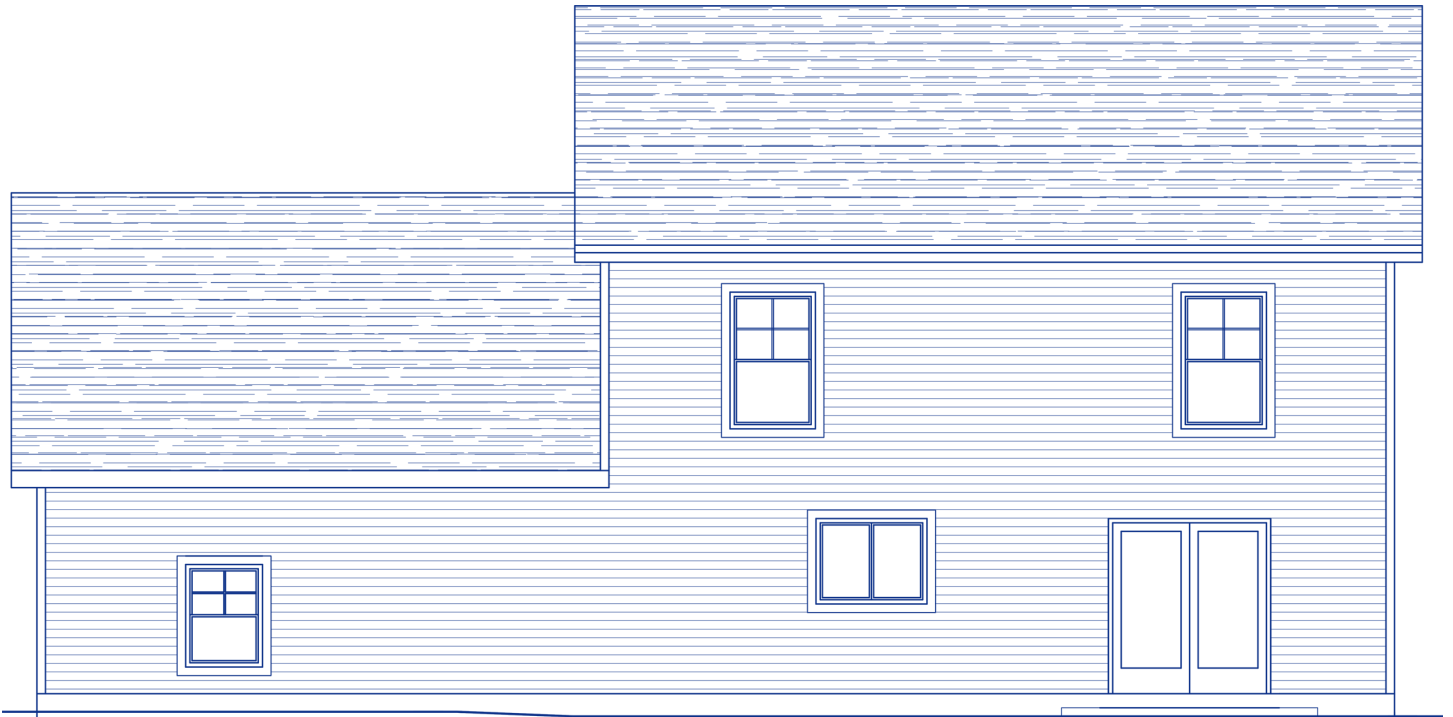

**The Ari – Left**

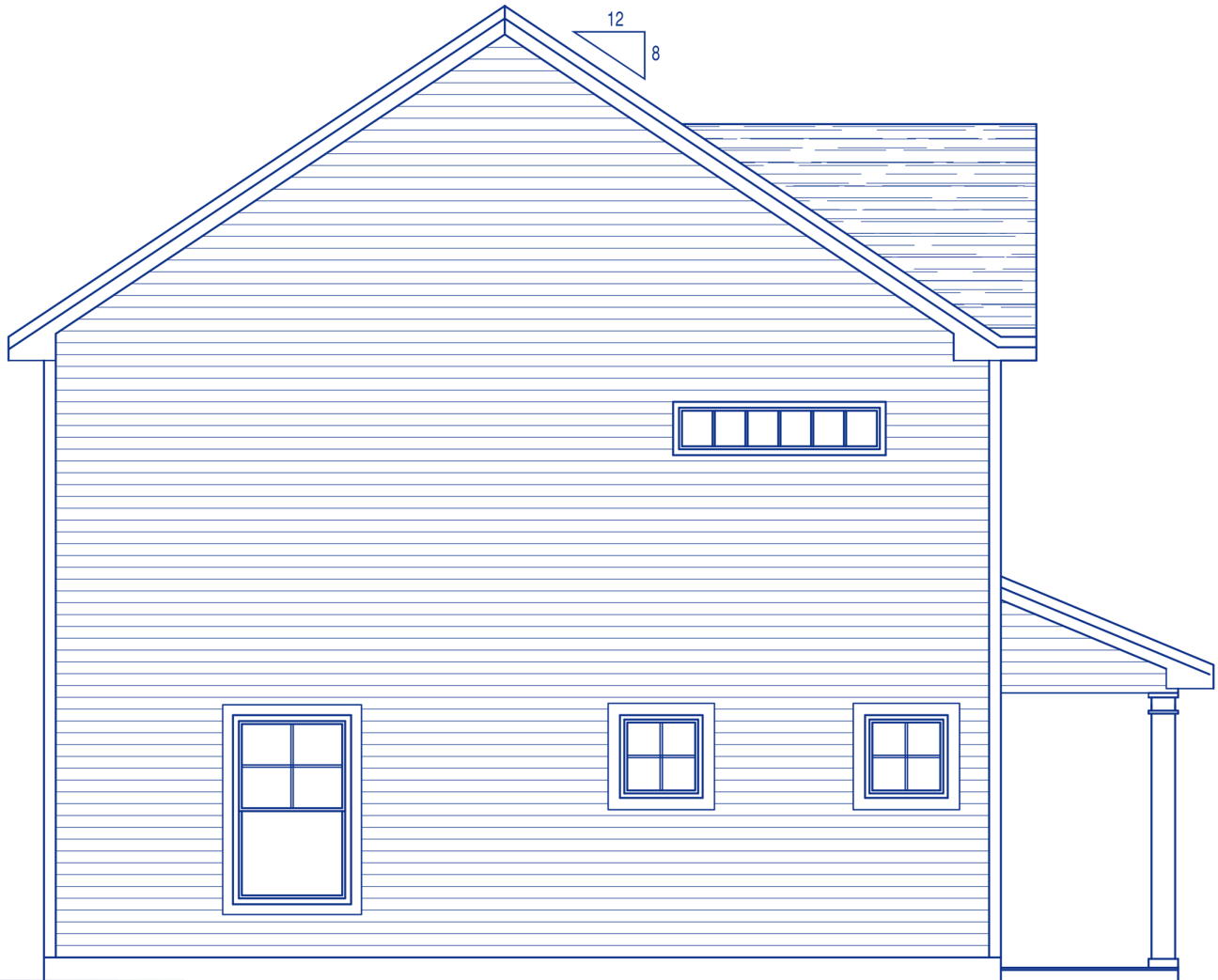

**The Ari – Right**

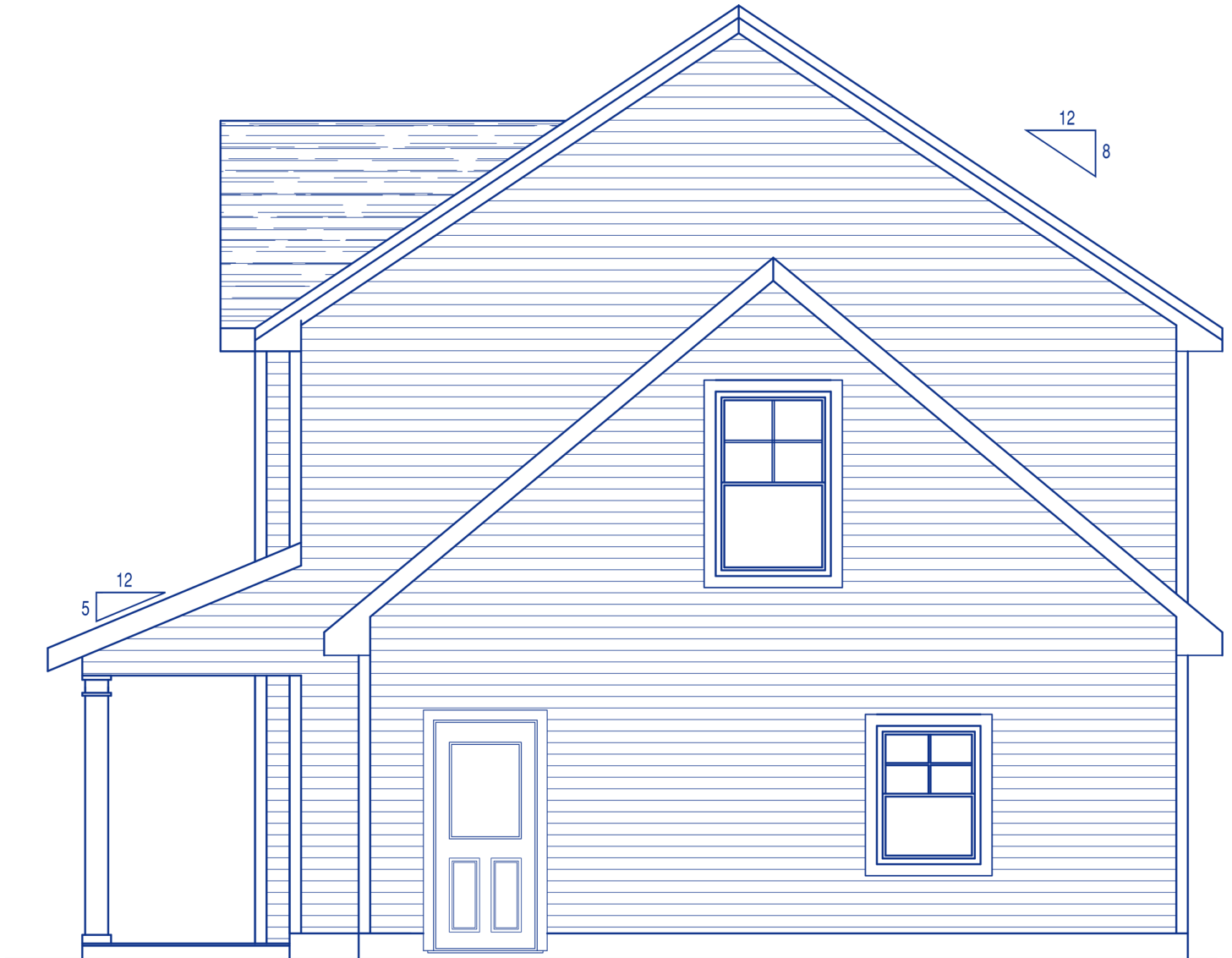



**The Ari – Second Floor**

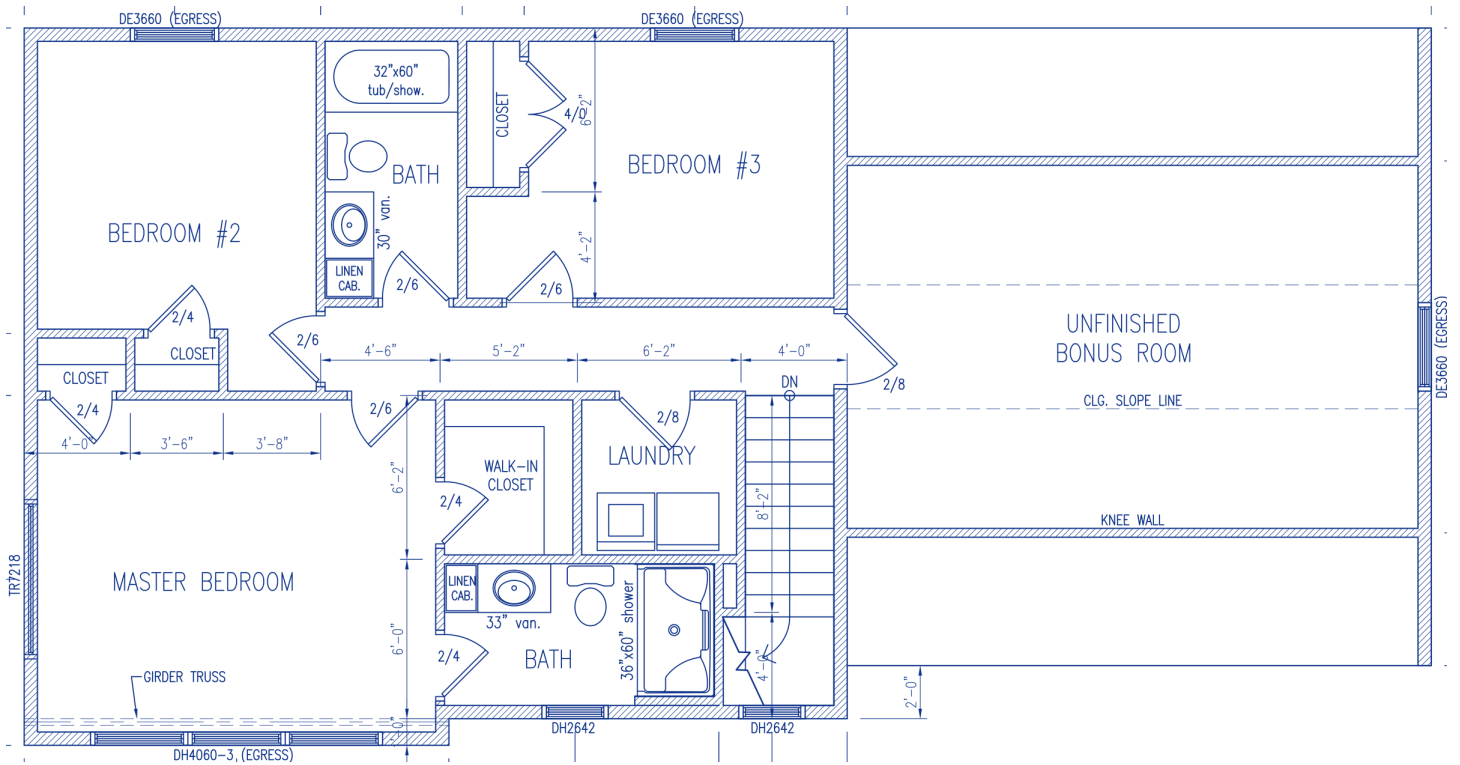

**The Ari – Foundation**

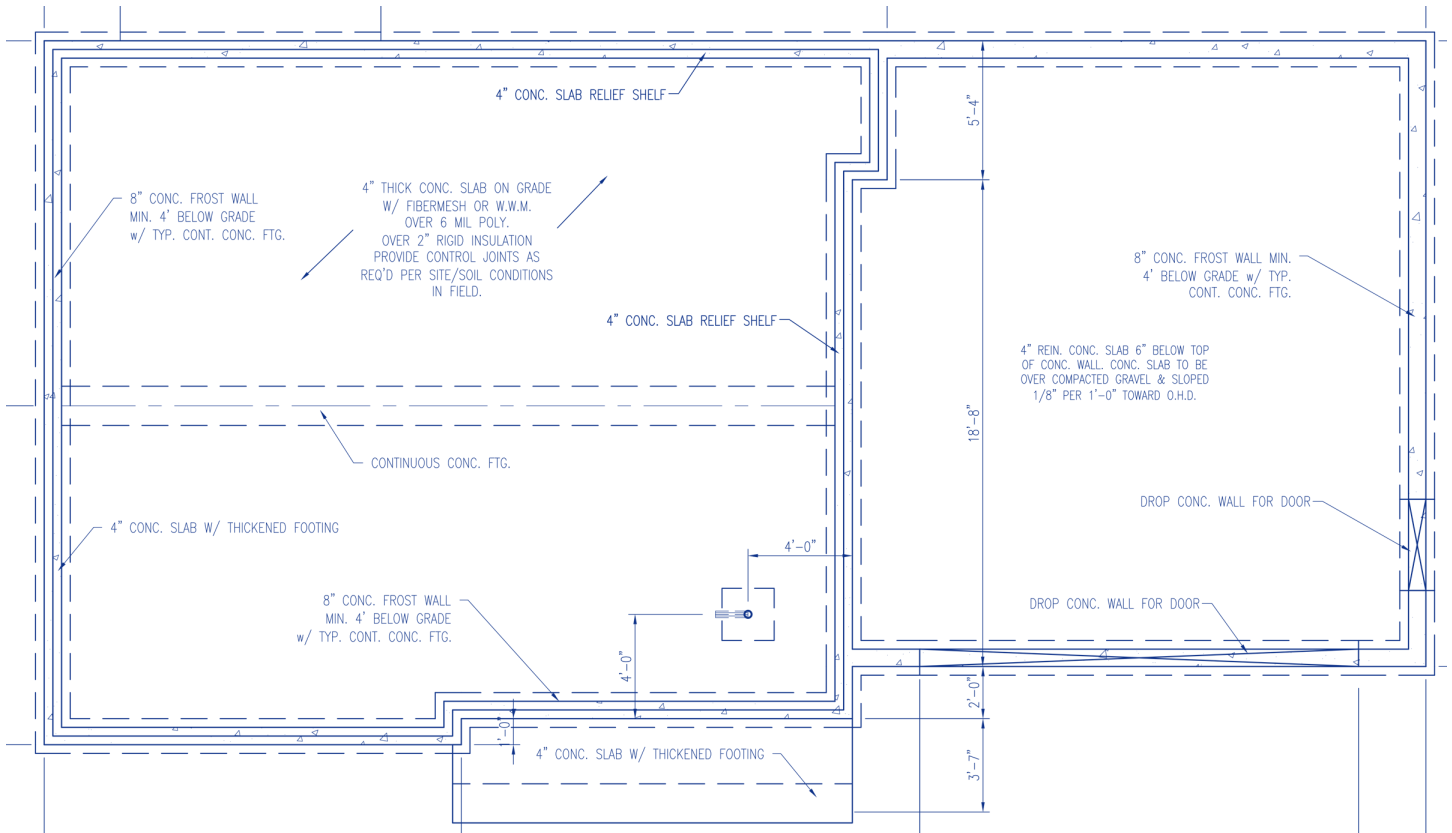

**The Ari – Cross-section 1**

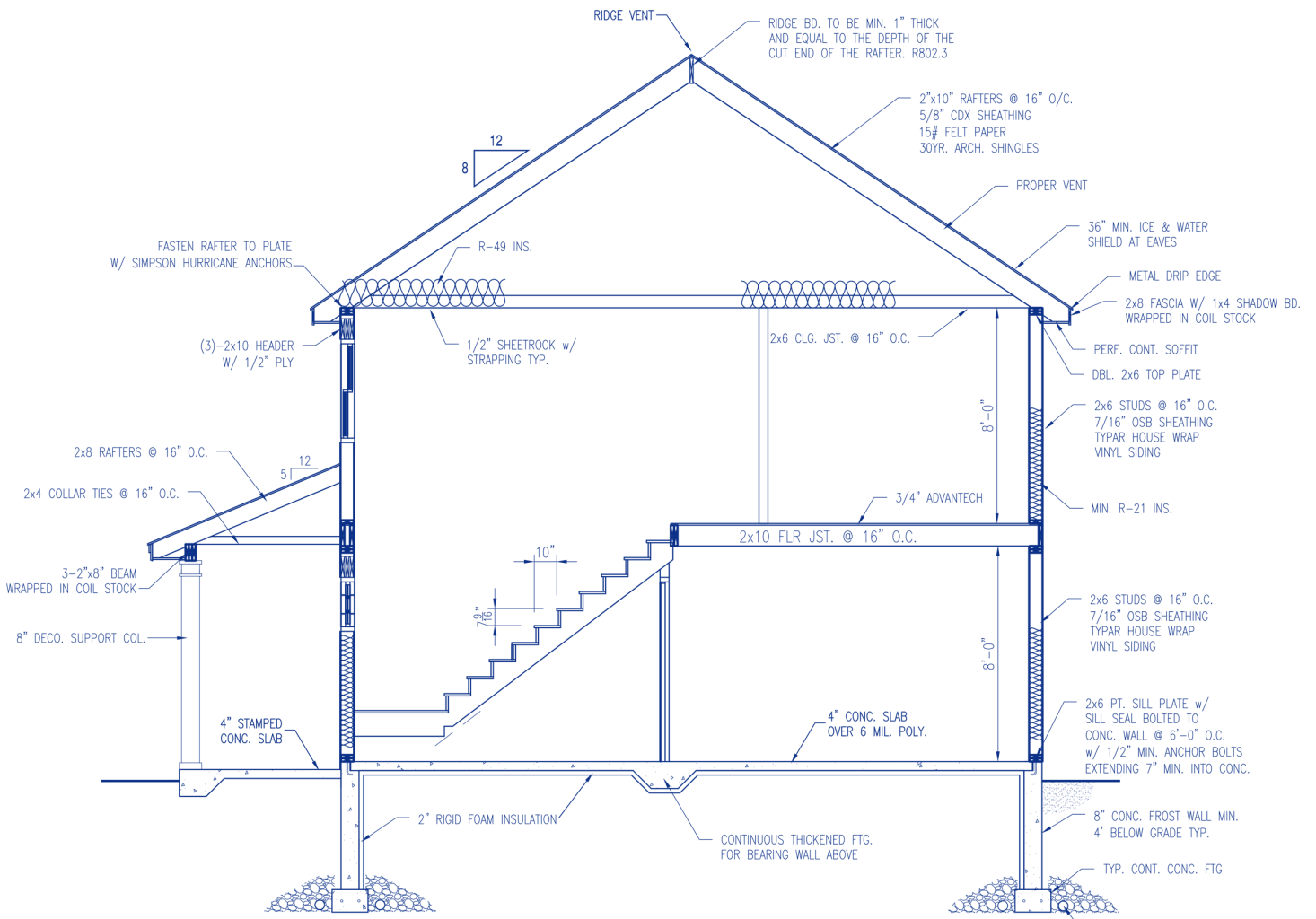



**The Ari – Cross-section 2**

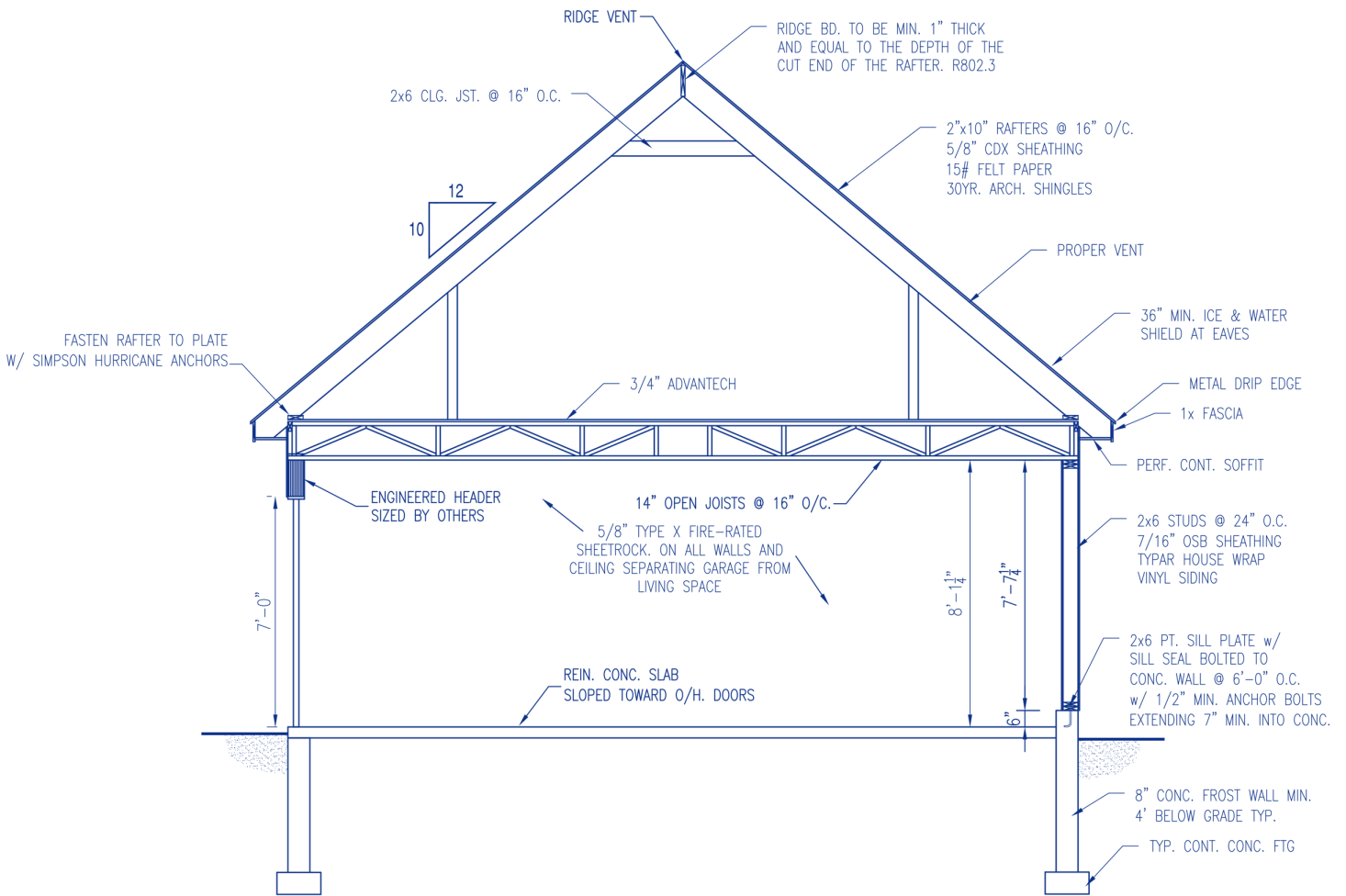

**Kitchen – Perspective 1**



**Kitchen – Perspective 2**



**Kitchen – Perspective 3**



## Kitchen Plan

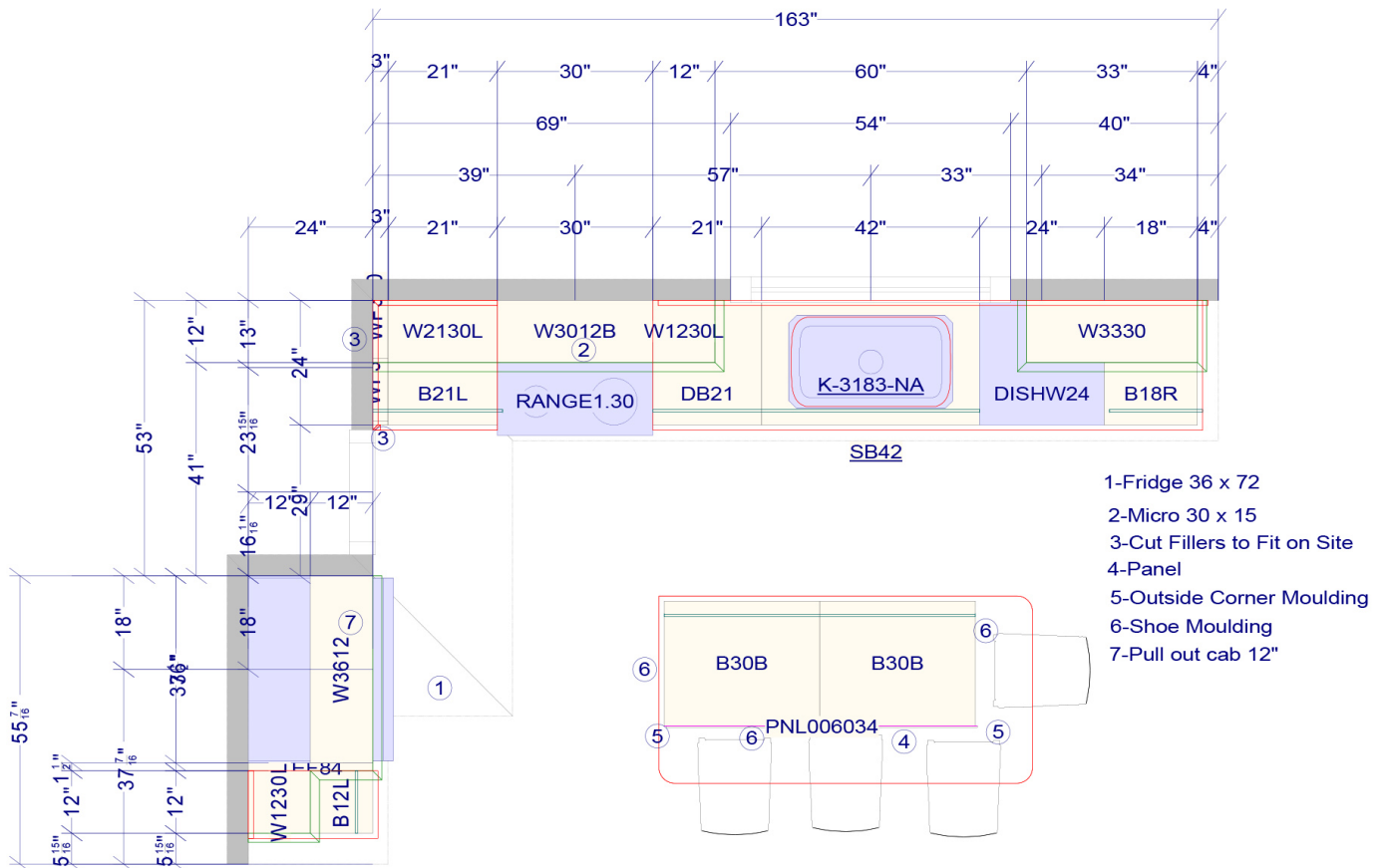

**Vanity**





**Vanity Plan**

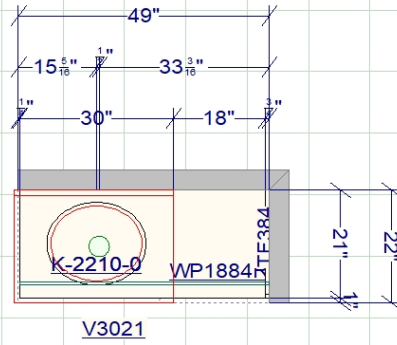
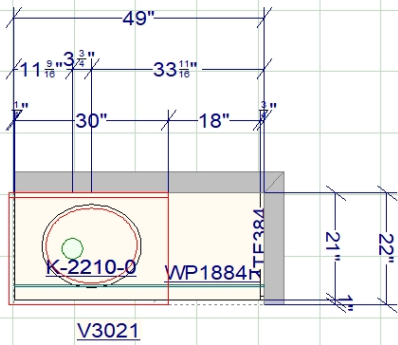

JSI Plymouth White Allwood No Drawers

Level One Granite Standard Edge and Backsplash  
with White Oval Undermount Bowls

Approved by: \_\_\_\_\_

Date: \_\_\_\_\_