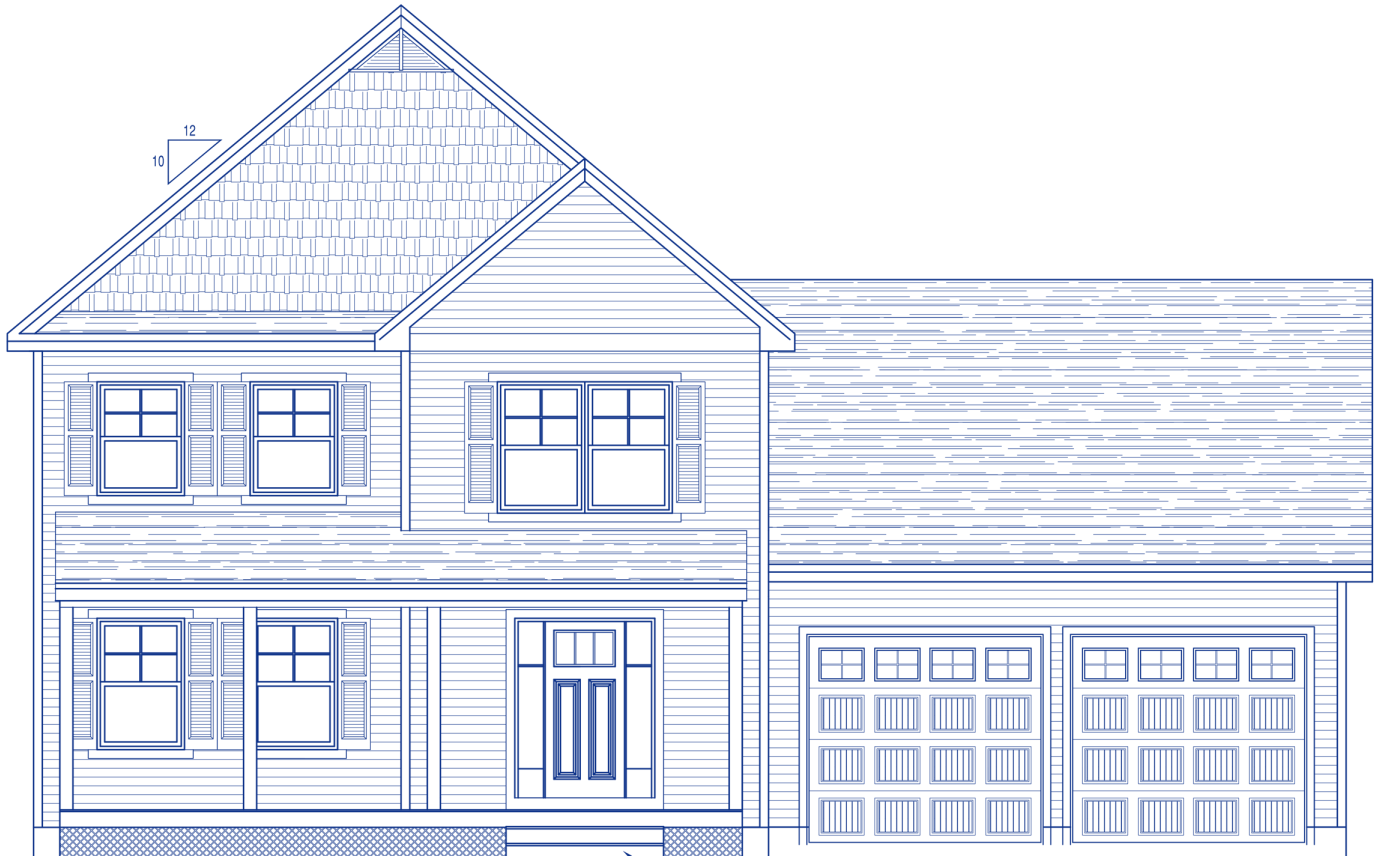

Exhibit B

The David (1,848 sq ft) – Front



The David – Rear



The David – Left



The David – Right

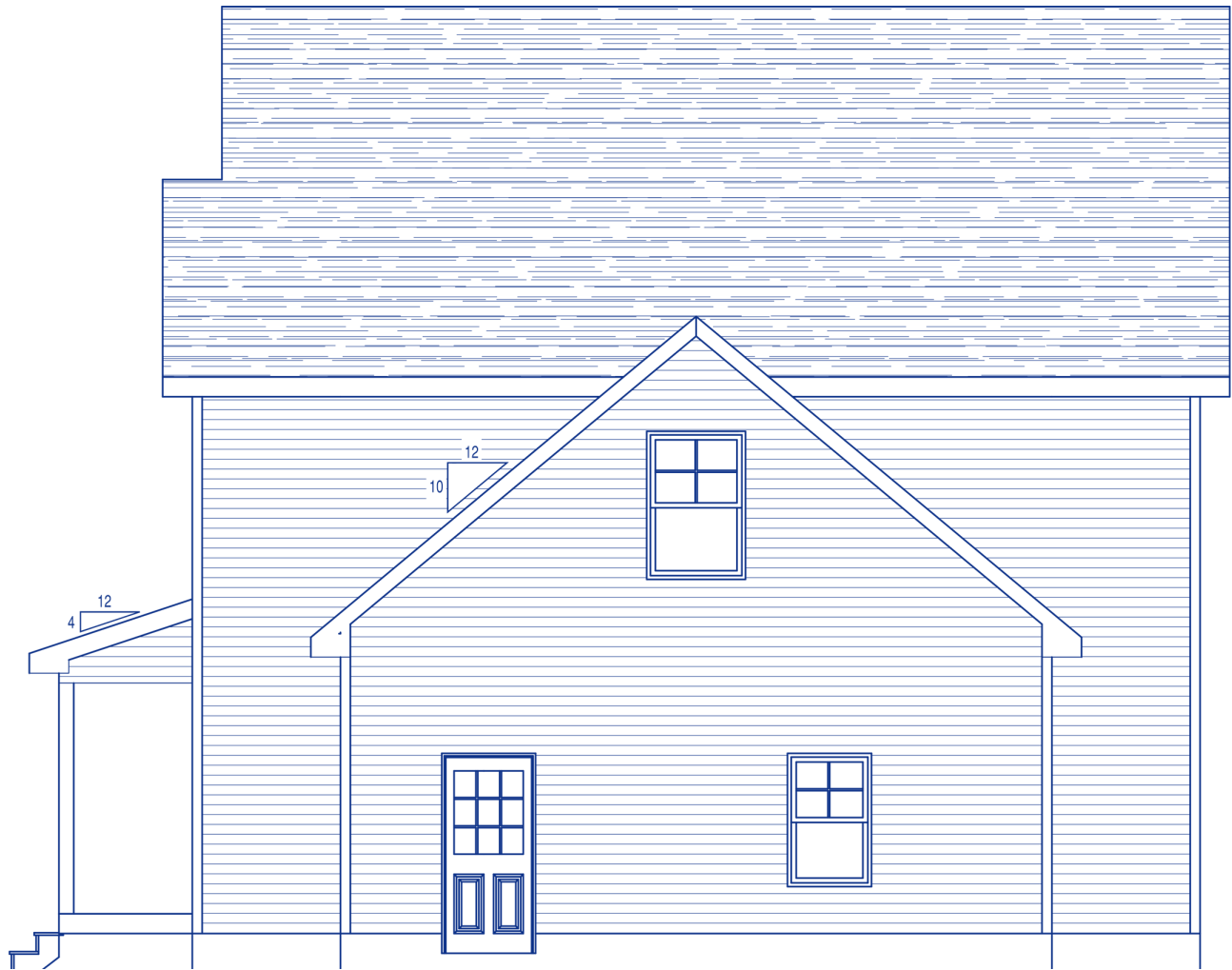

The David – First Floor Plan

12x12 Patio

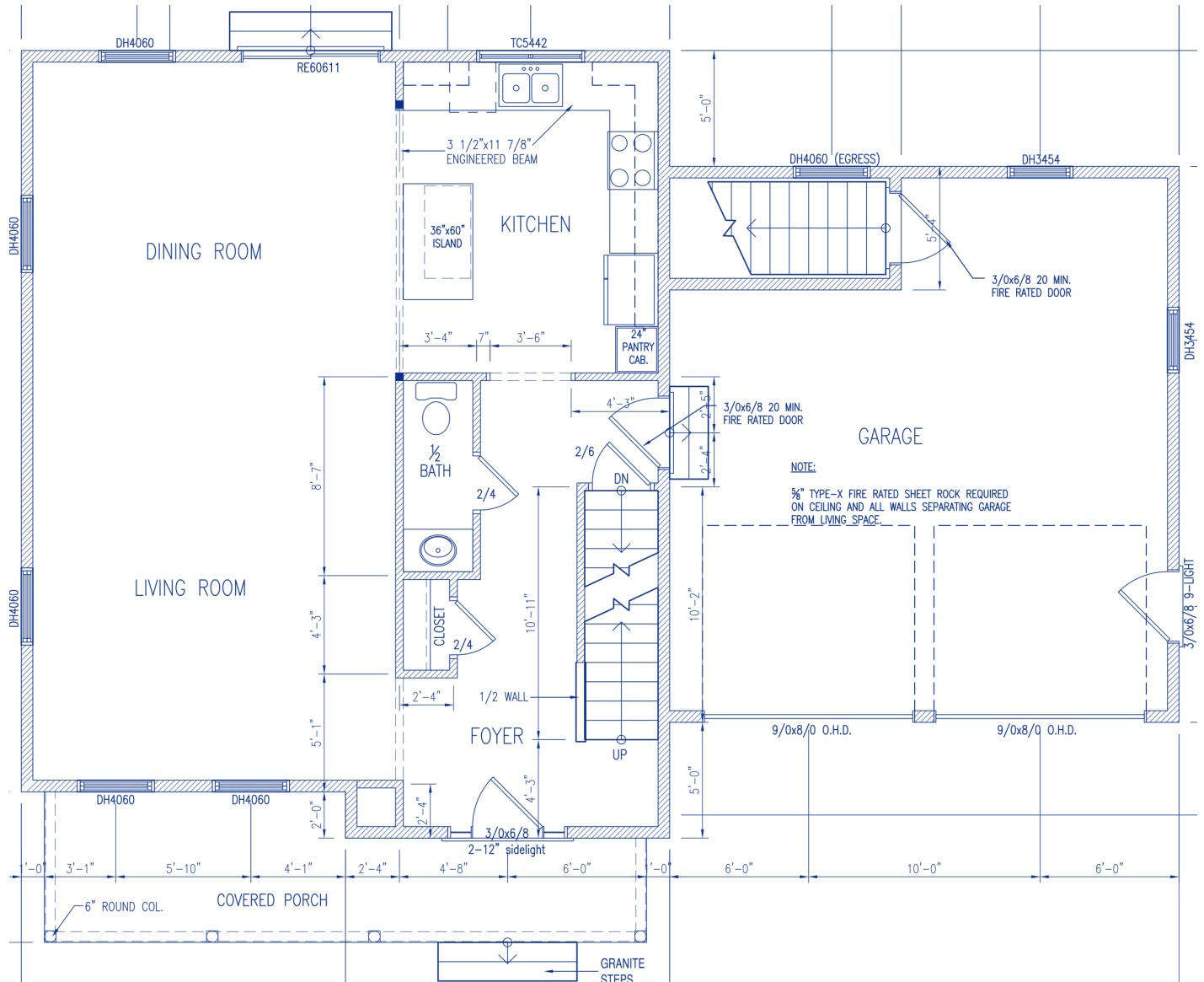

The David – Second Floor Plan

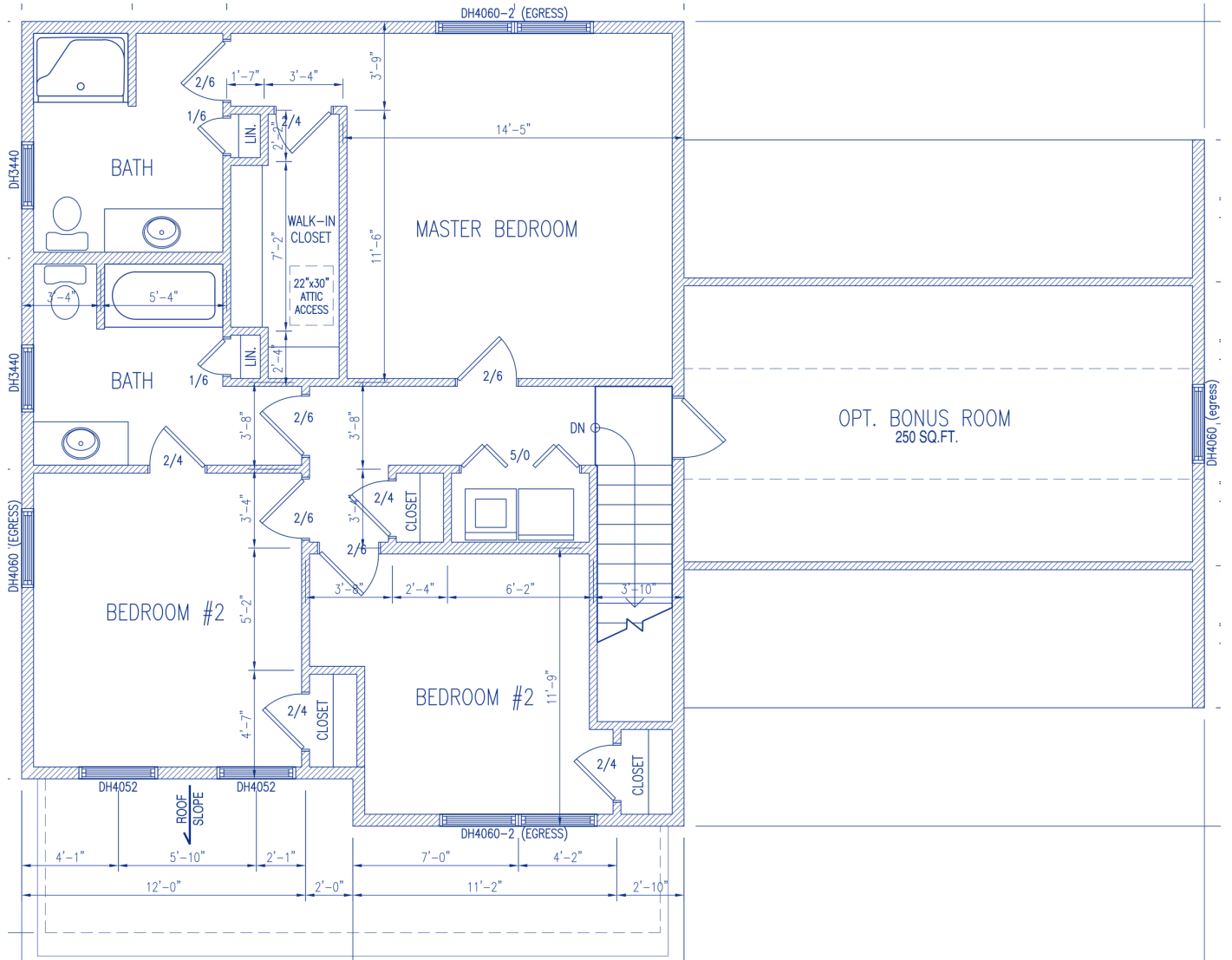

The David – Foundation Plan

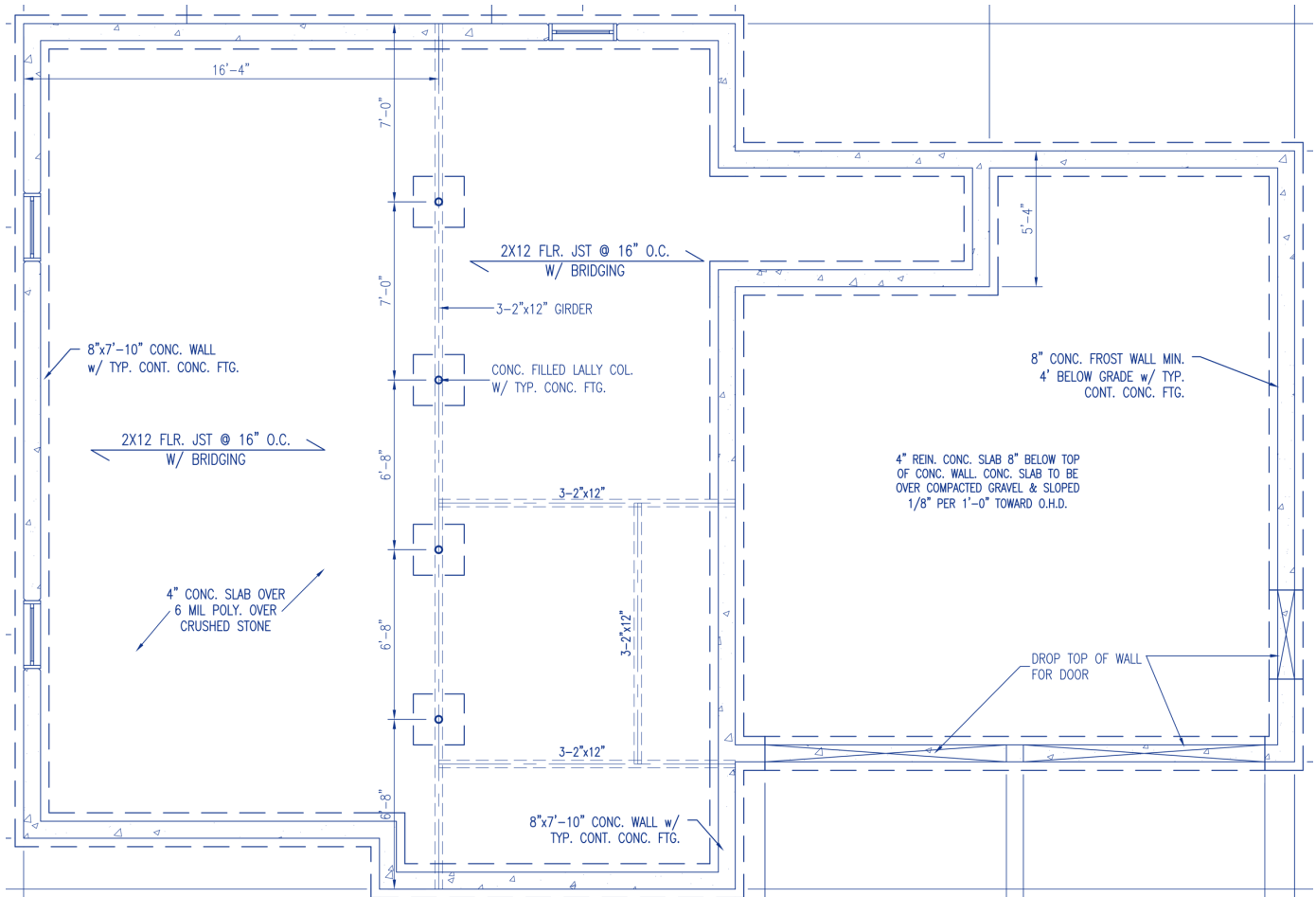

The David – Cross-section

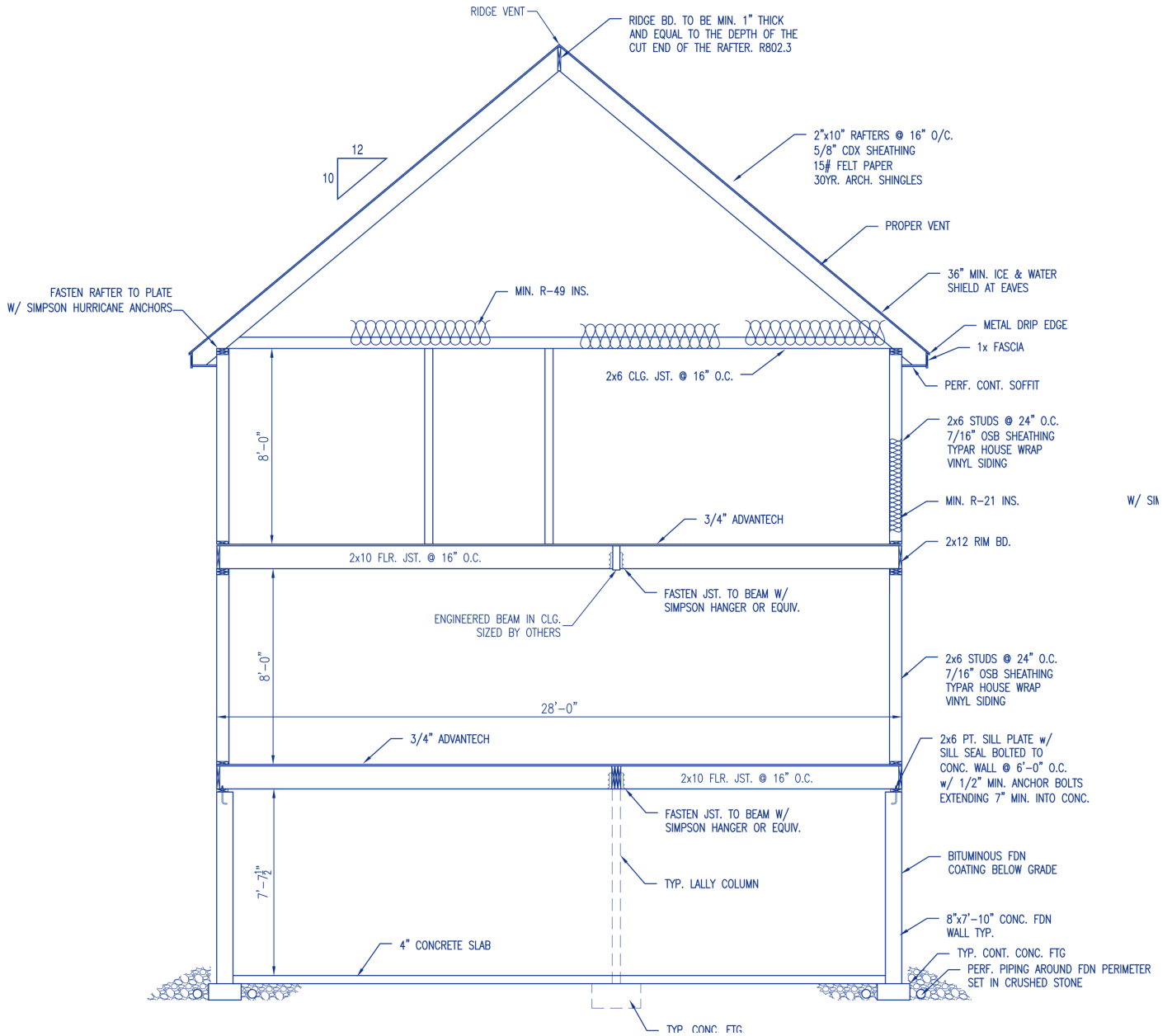

Kitchen – Perspective 1



Kitchen – Perspective 2



Master Vanity



Guest Vanity



Kitchen Plan

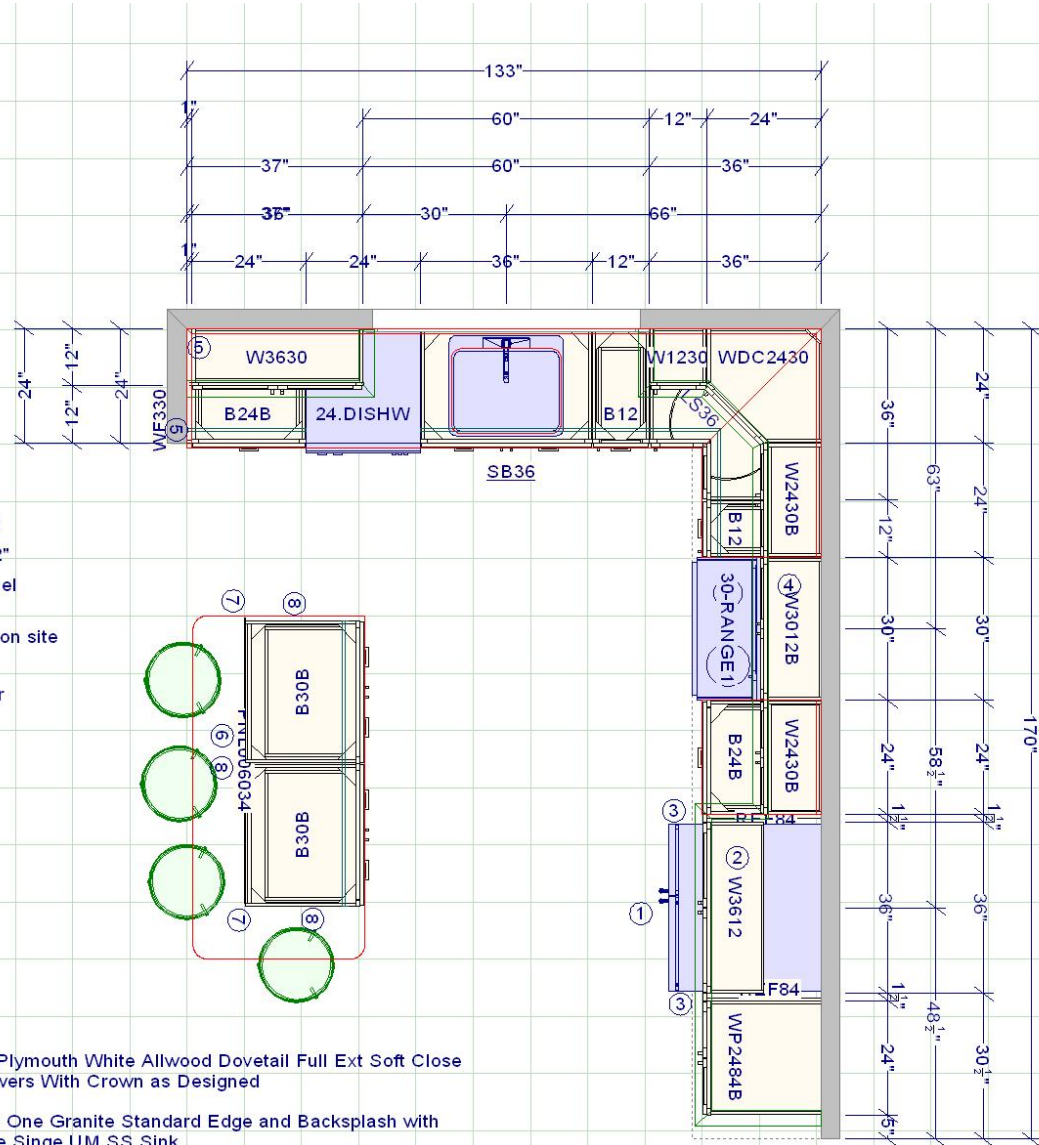

Vanity Plans

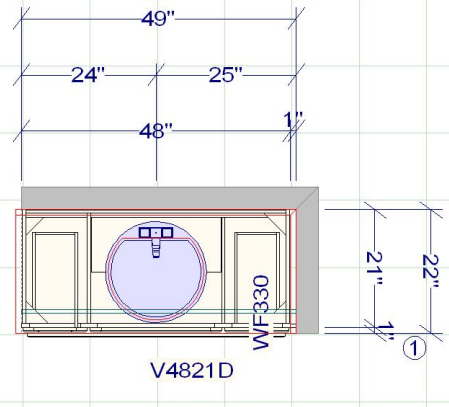
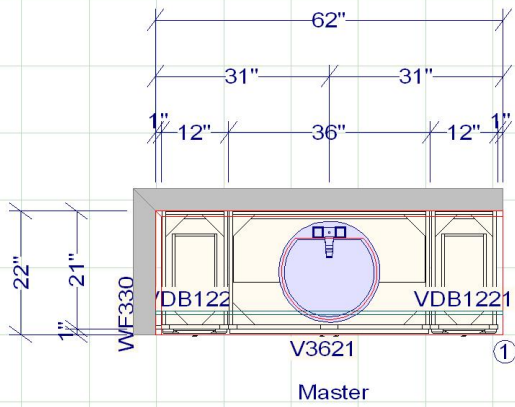

1-Cut Fillers to Fit on Site

Guest

JSI Plymouth Allwood Dovetail 3/4 Ext Side Mount Glides as Designed

Vanity Level One Granite Standard Edge and Backsplsh with White UM Bowls

Approved by: _____

Date: _____