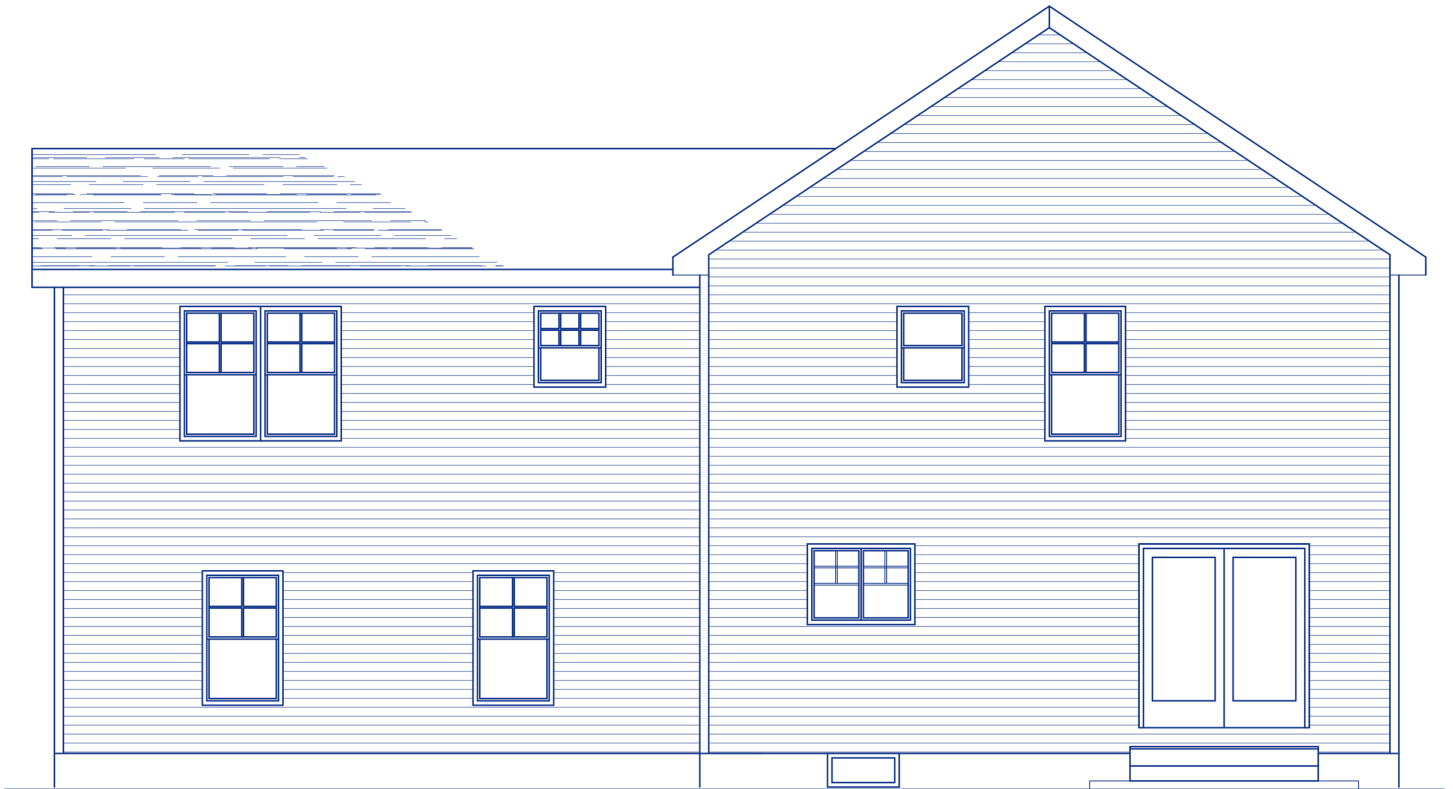

Exhibit B

**The Will (2,122 sq ft) – Front**



**The Will – Rear**



**The Will – Left**

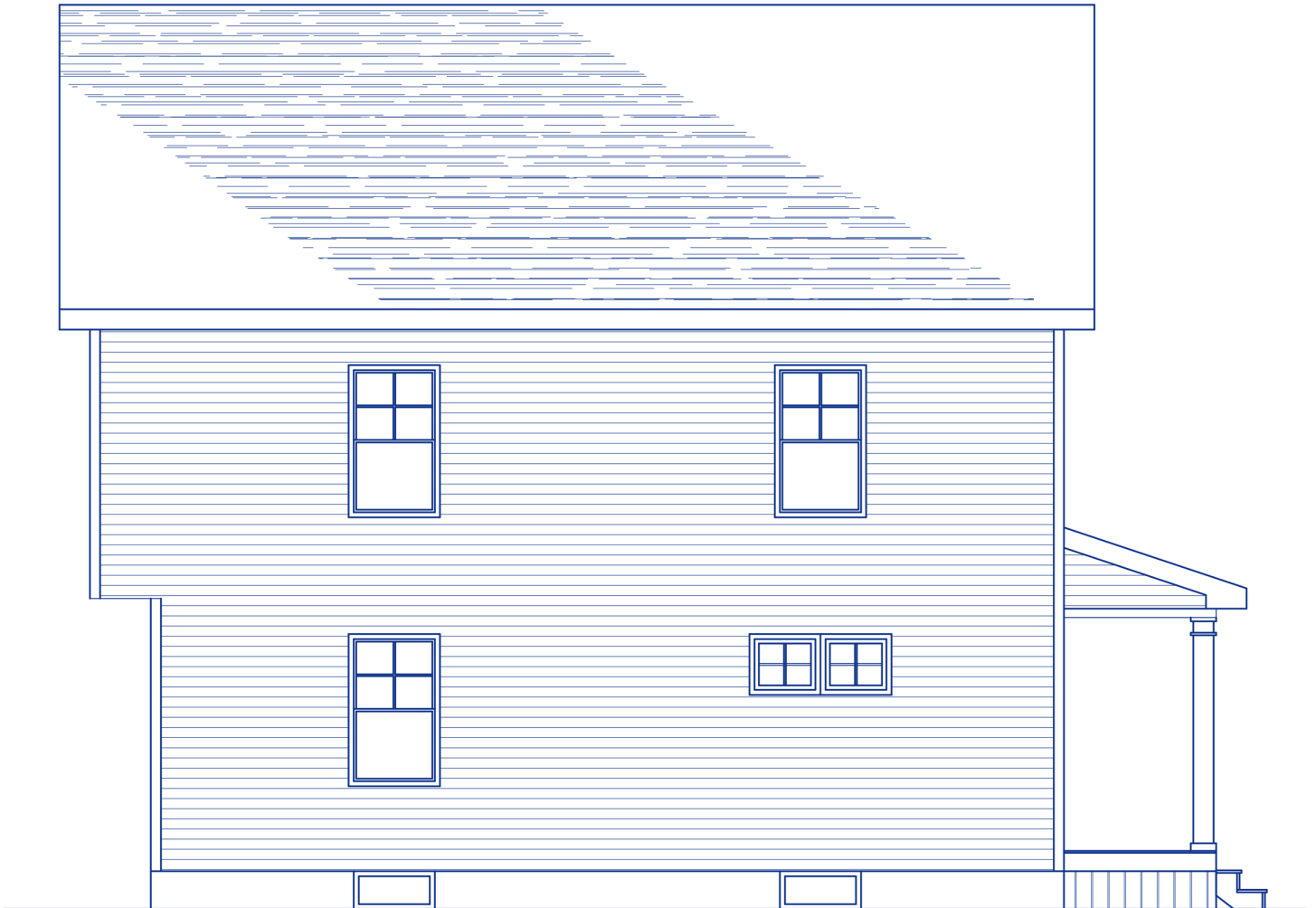

**The Will – Right**

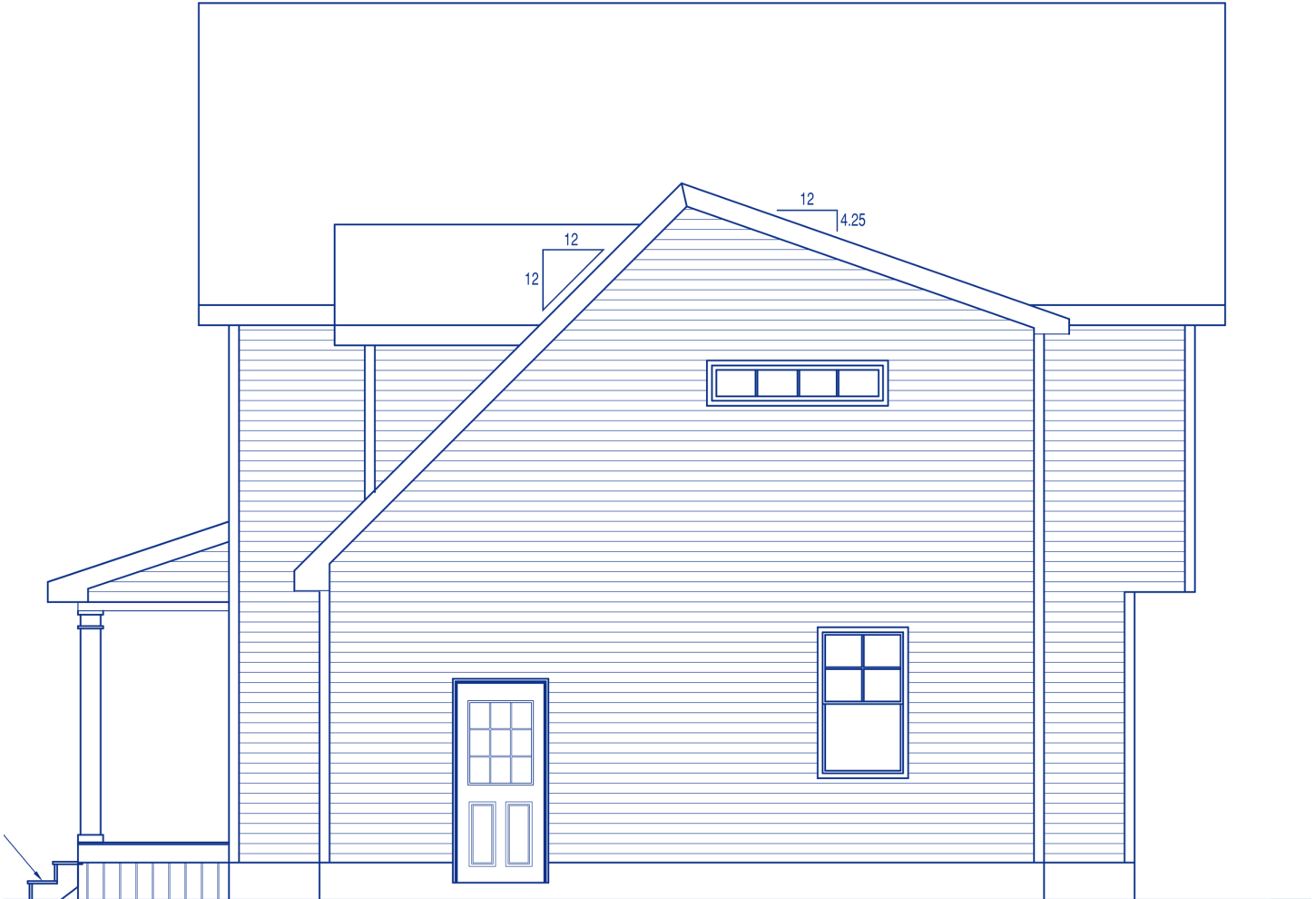

**The Will – First Floor Plan**

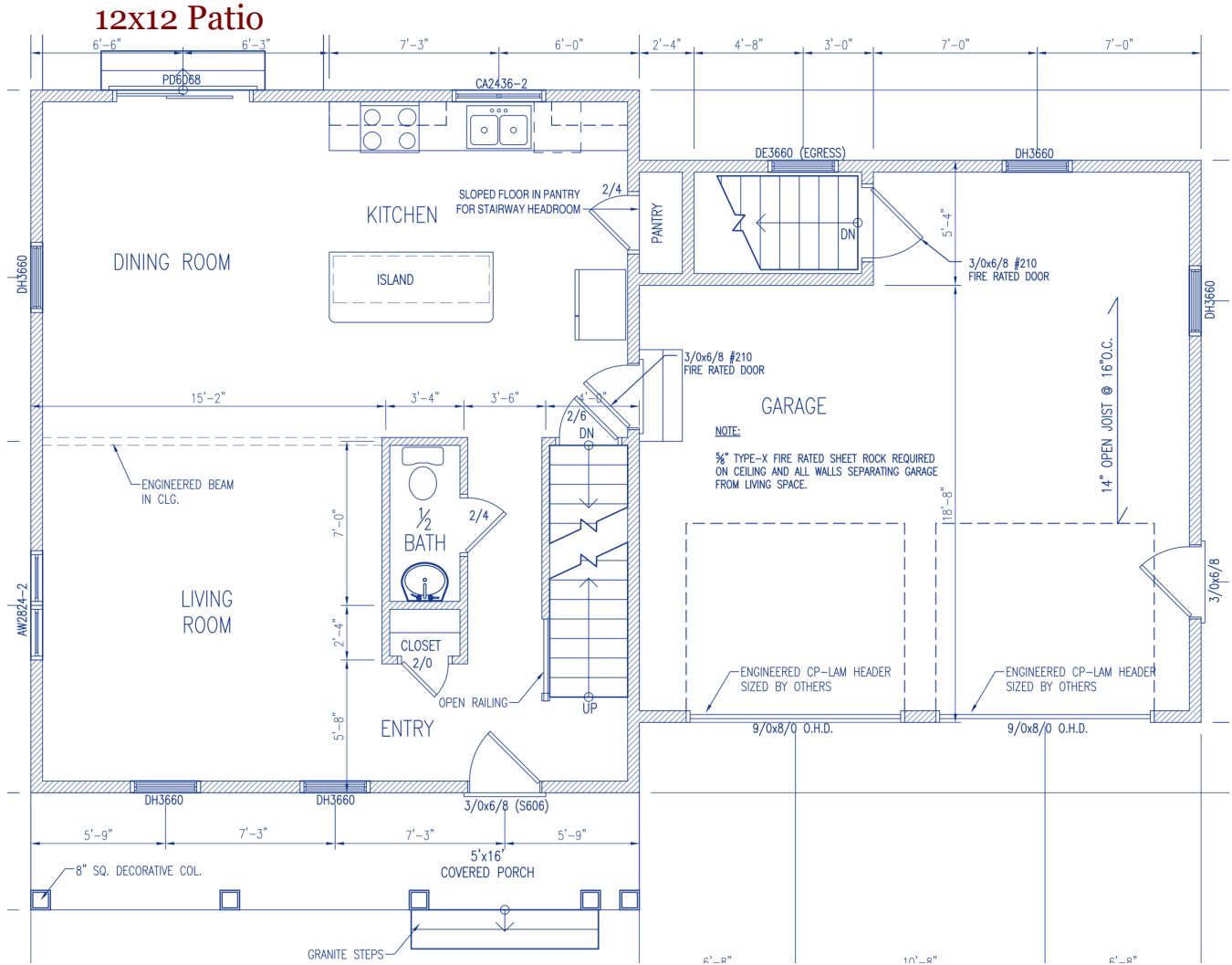

### The Will – Second Floor Plan

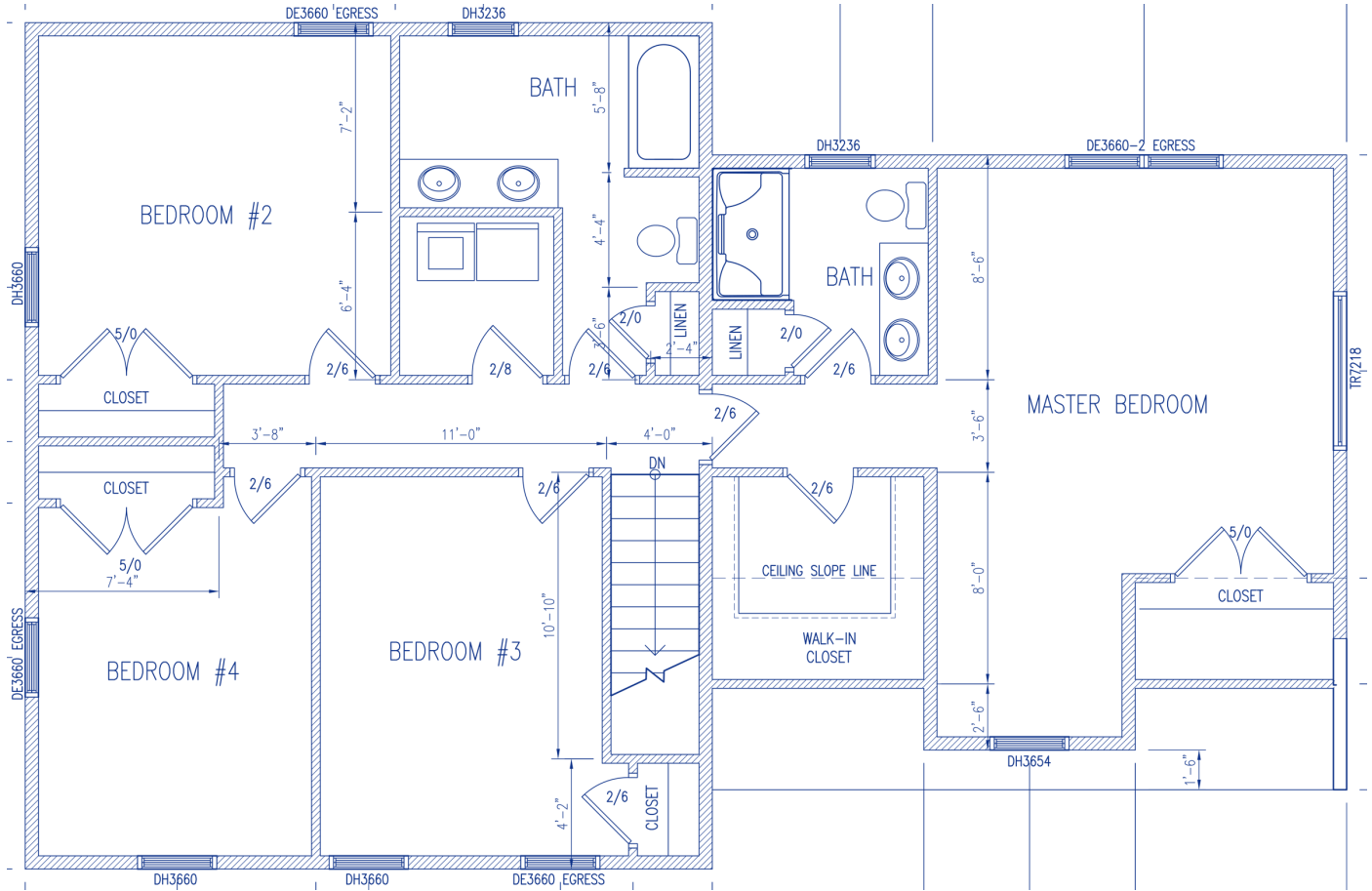

**The Will – Foundation Plan**

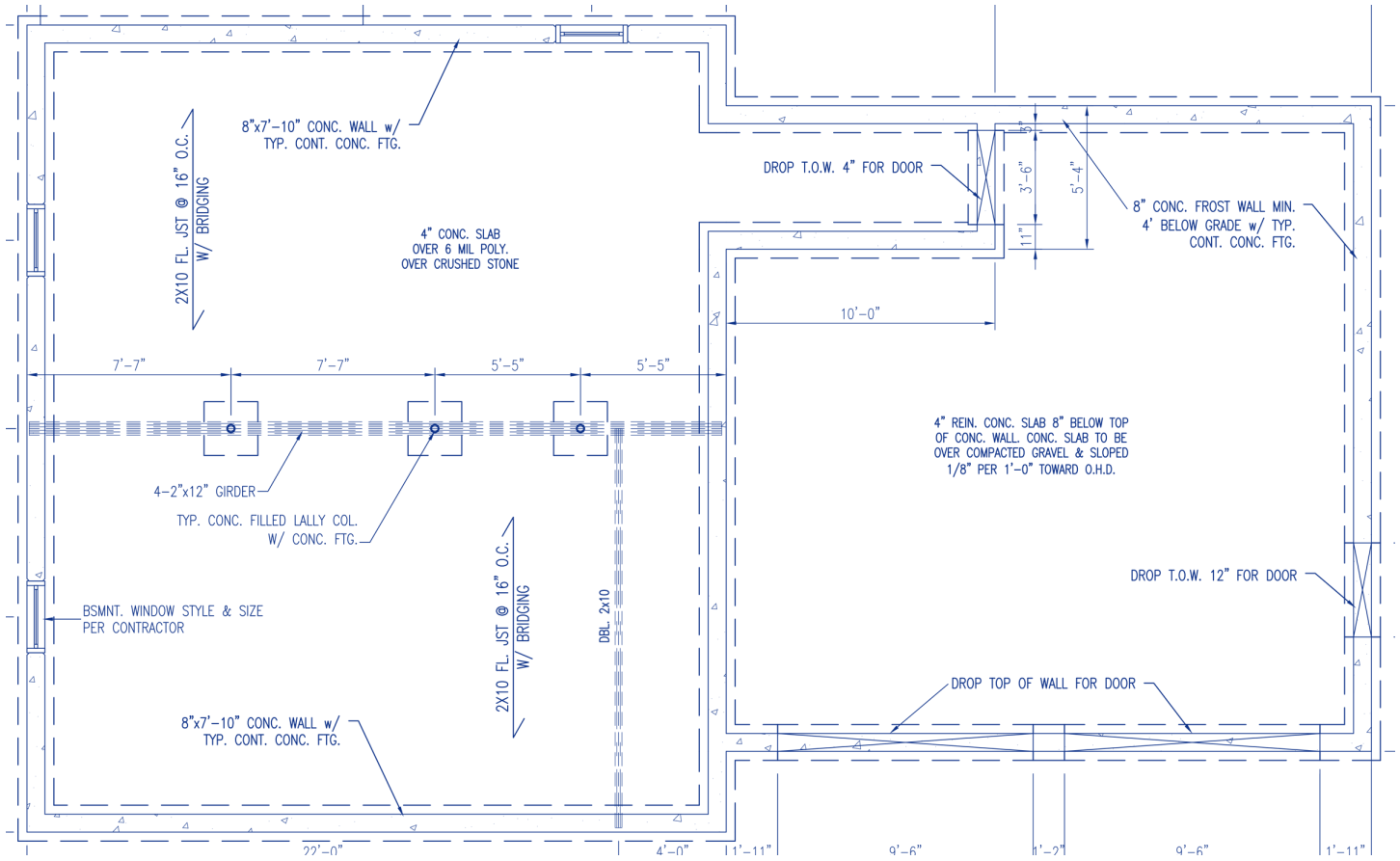

**The Will – Cross-section**

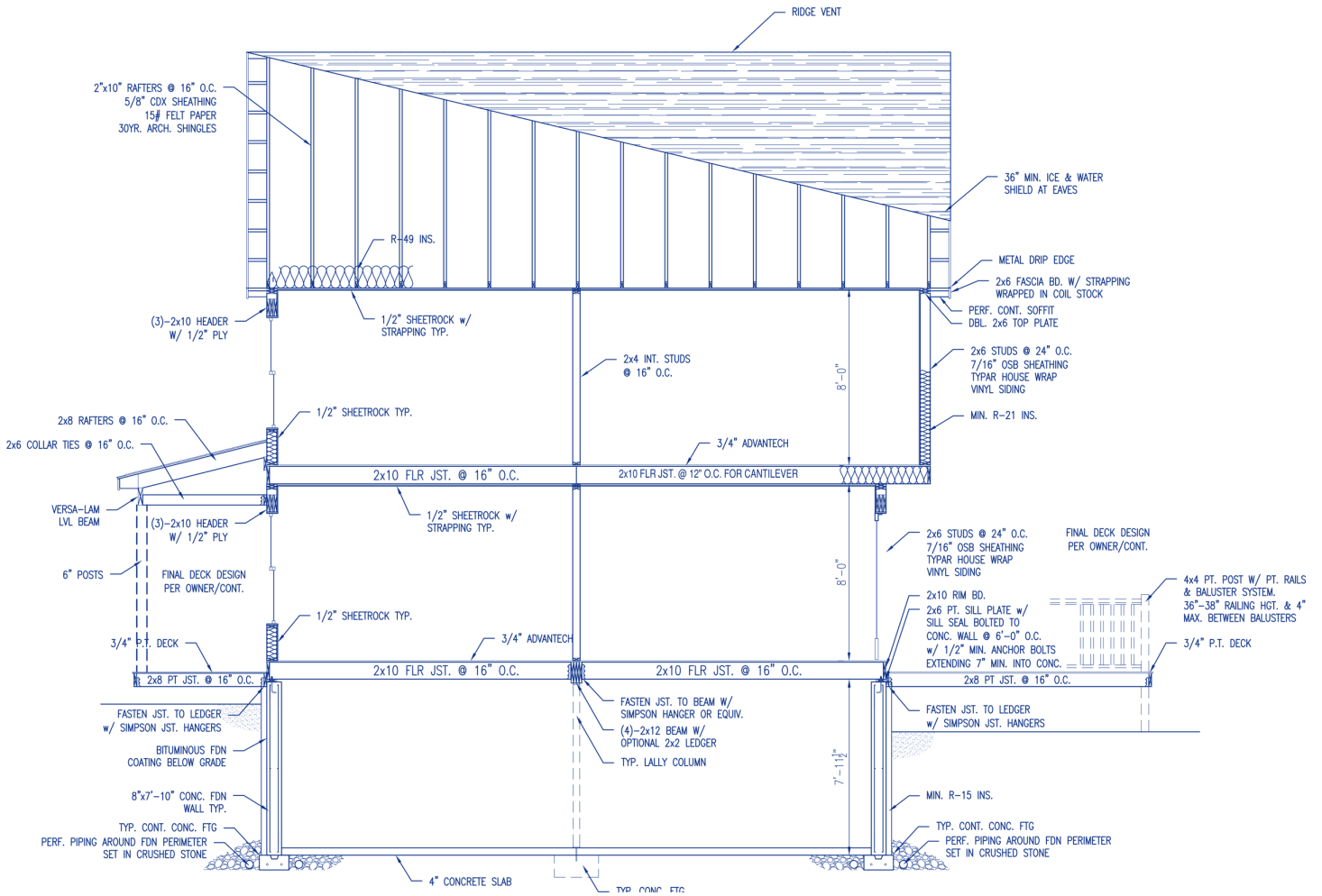



**Master Vanity**



**Guest Vanity**



Vanity Plan

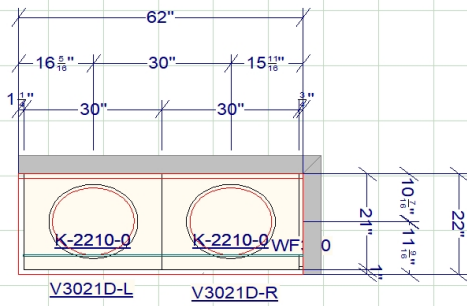

Master

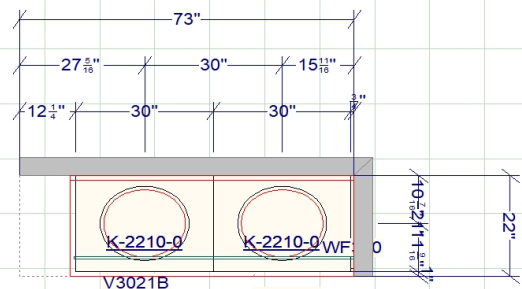

Guest

JSI Plymouth White Allwood Construction Dovetail Full Ext Soft Close Drawers (Master Only) as Designed

Vanity Level One Granite Standard Edge and Backsplsh with White UM Bowls

Approved by: \_\_\_\_\_

Date: \_\_\_\_\_