

The St James (2,263 sq ft) – Front

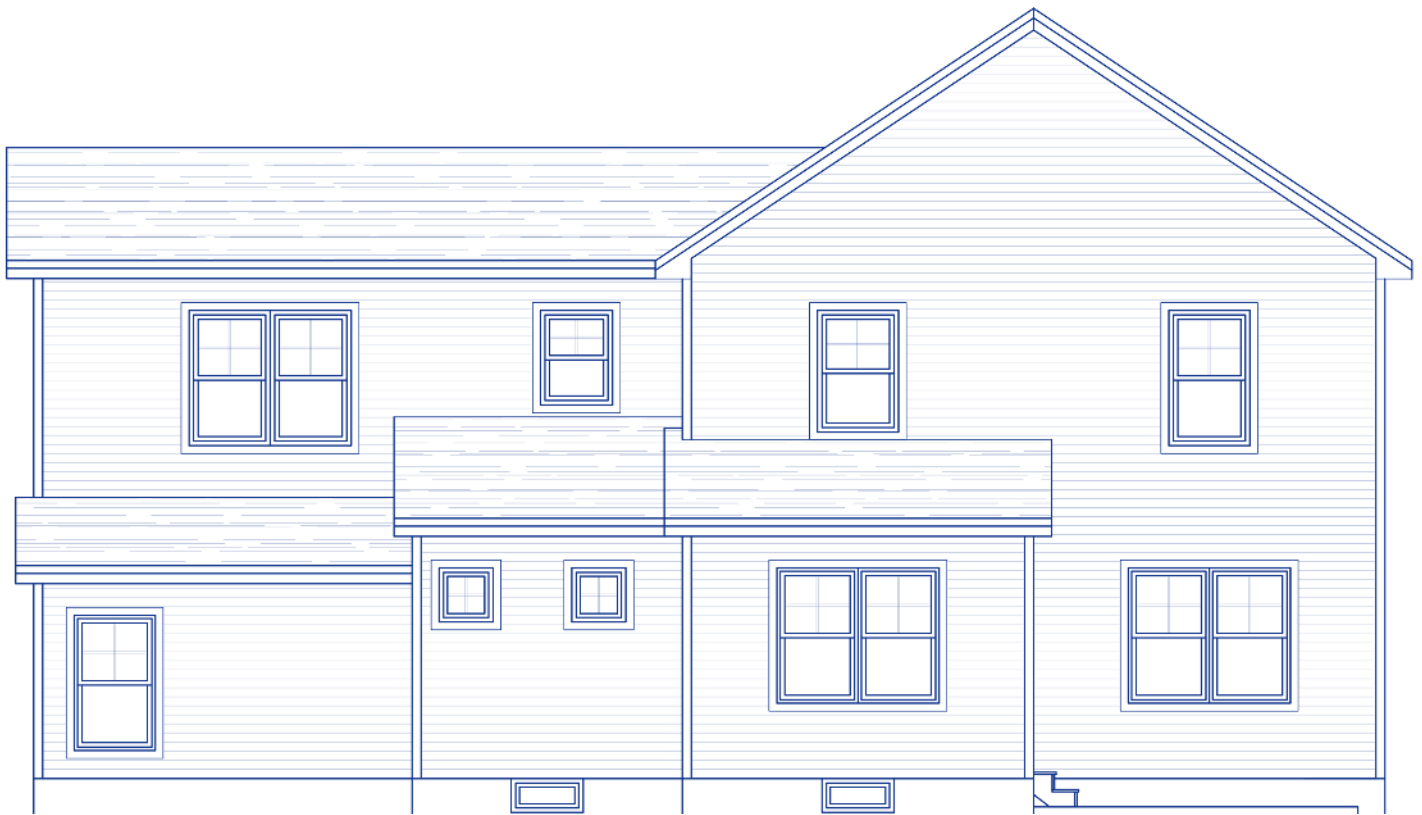

The St James – Rear



The St James – Left

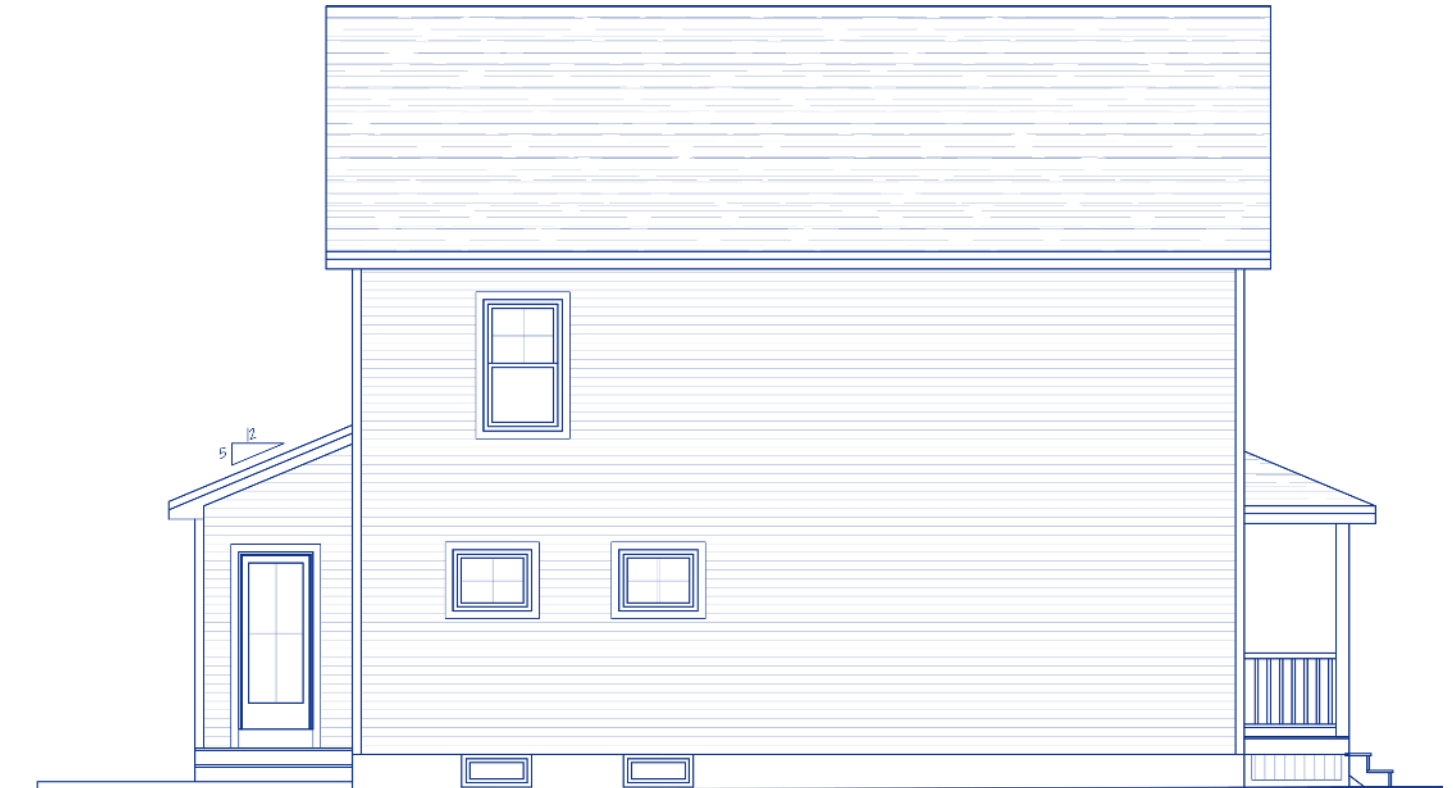

The St James – Right

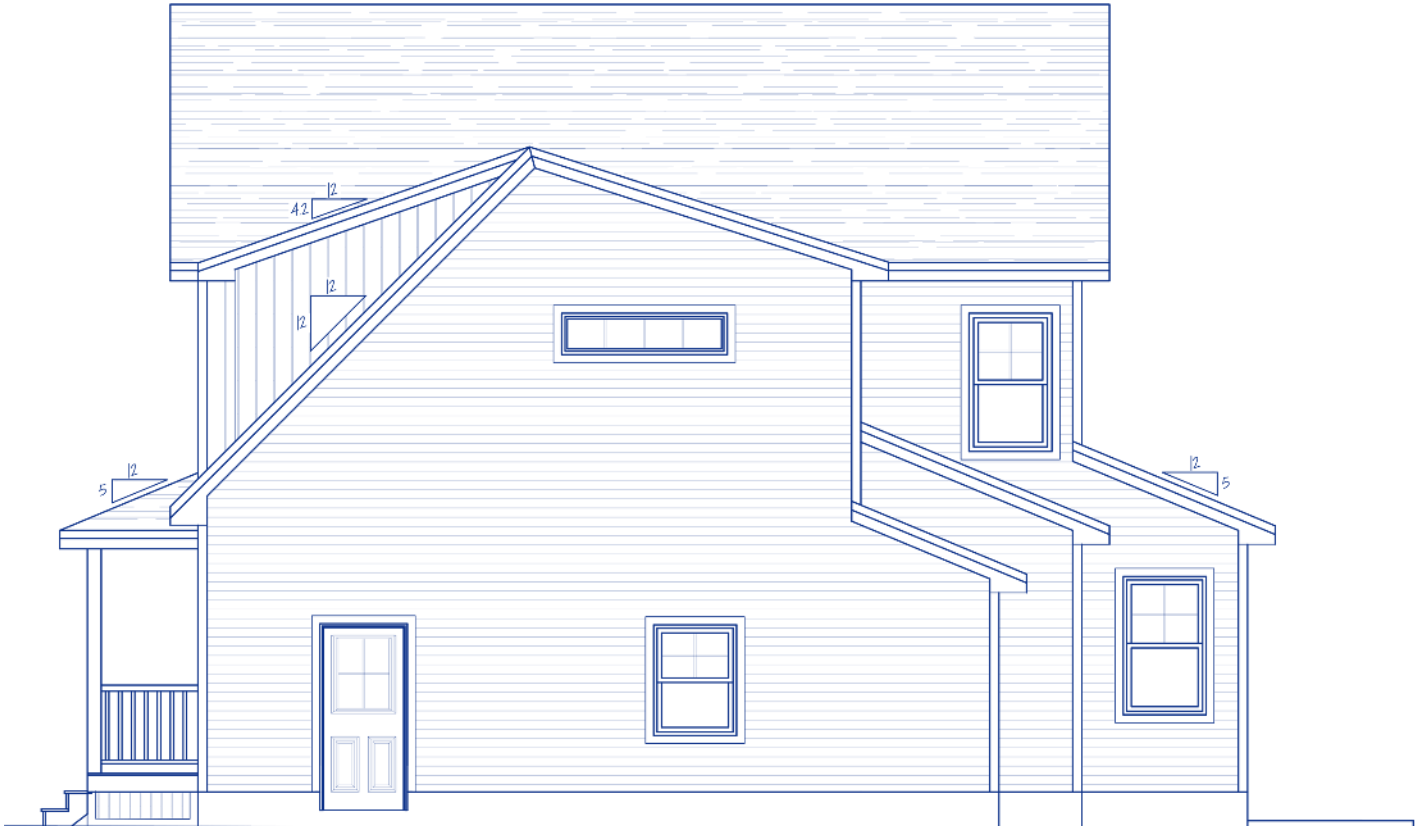

The St James – Cross-section 1

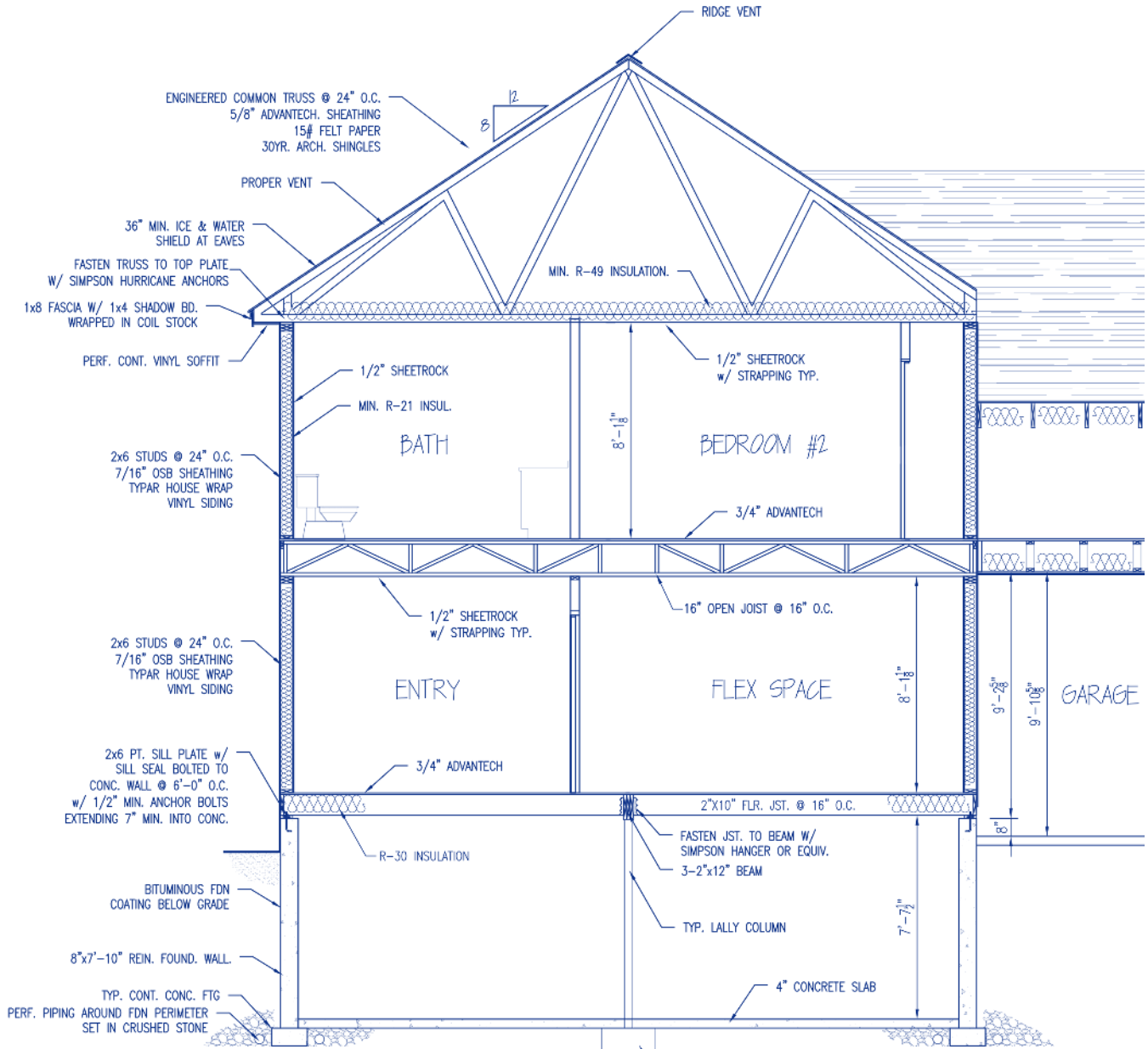

The St James – Cross-section 2

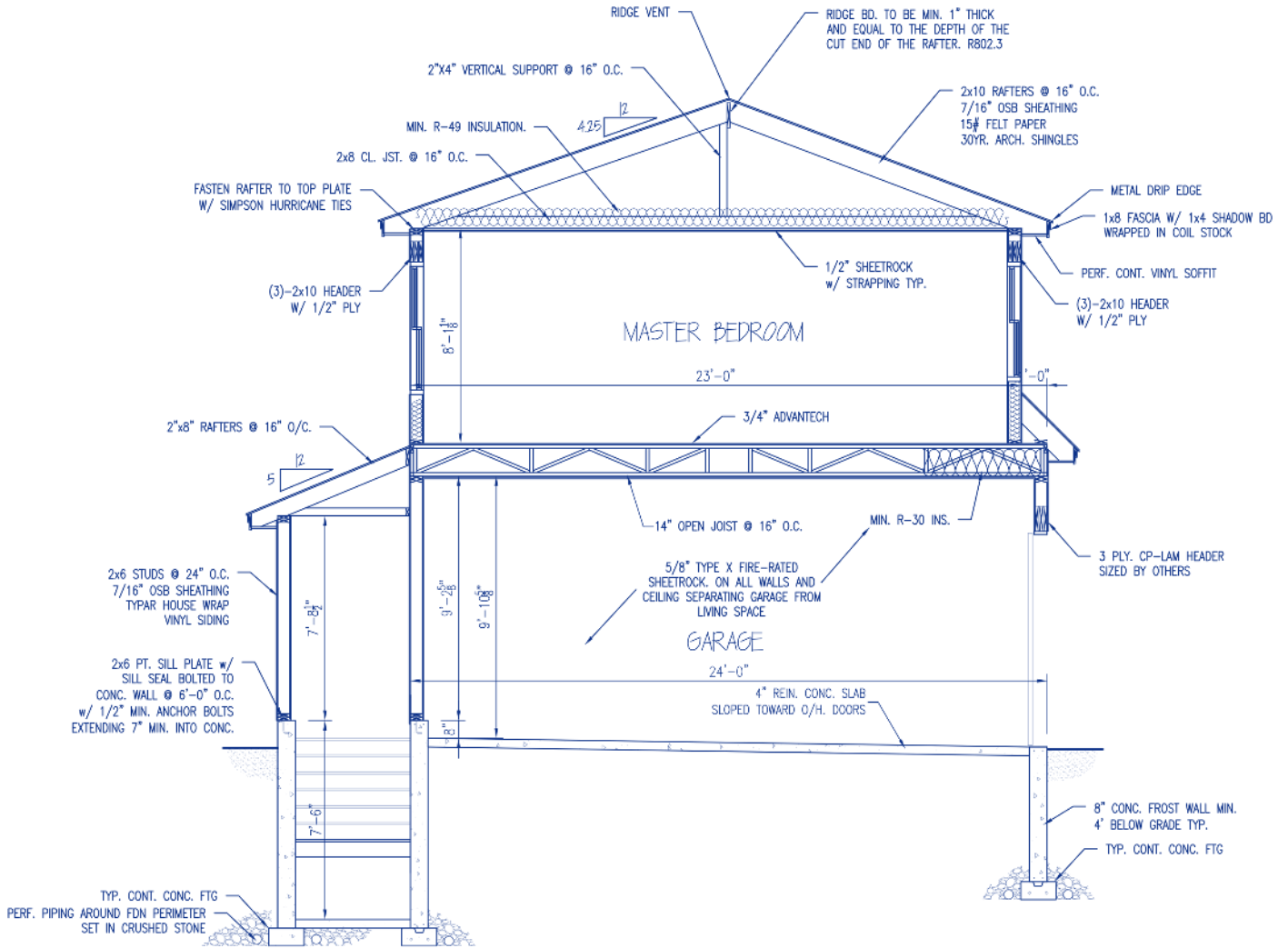

Entryway



Kitchen Perspective 1

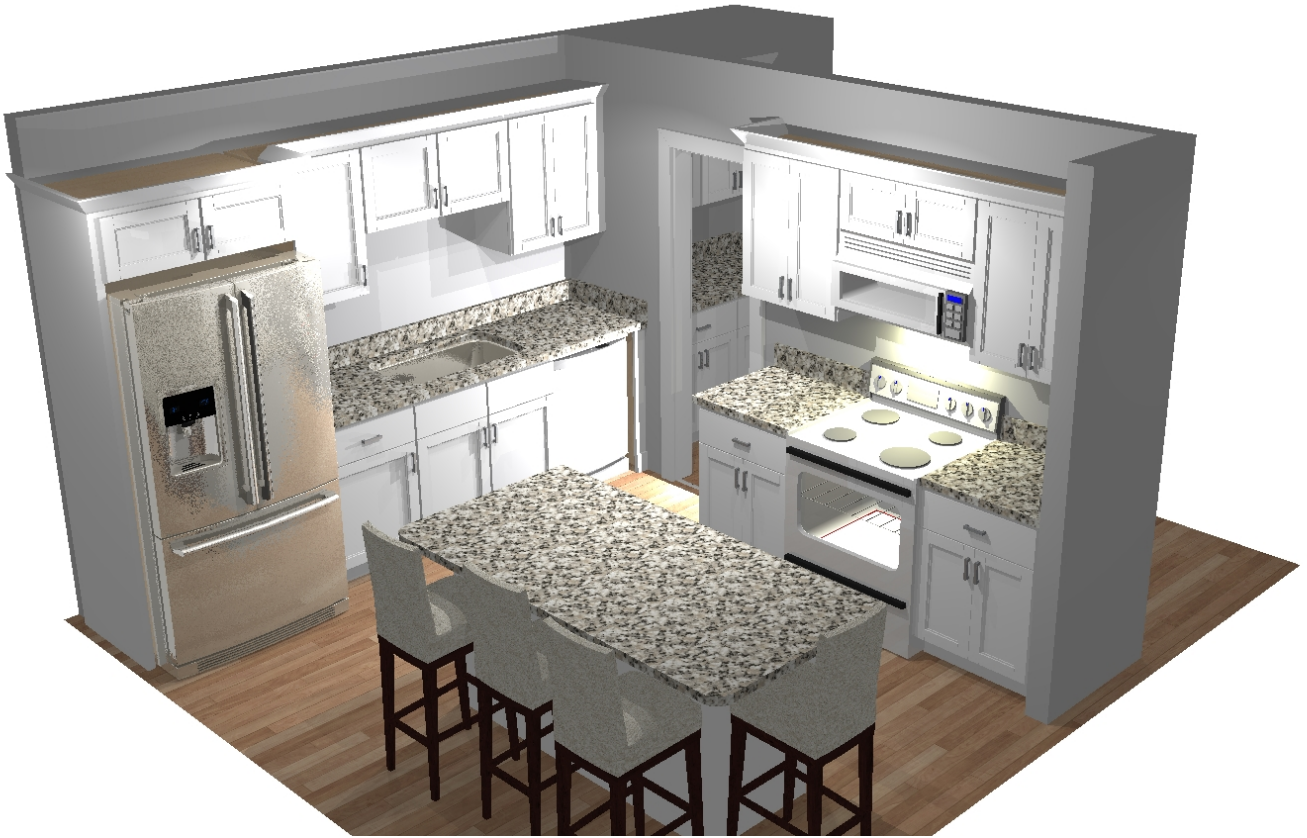

Kitchen Perspective 2



Kitchen Perspective 3



Kitchen Plan

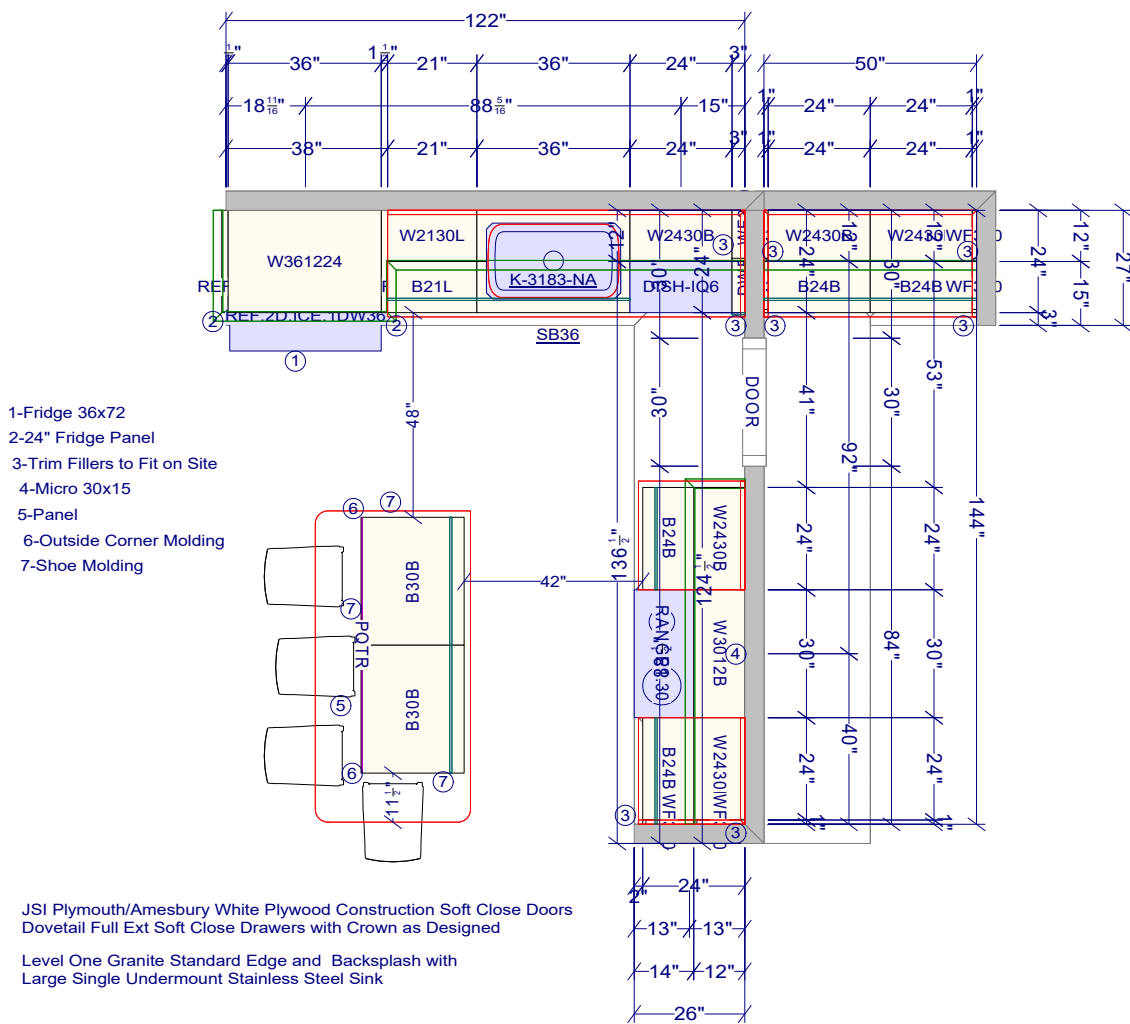

Vanities



Vanity Plan

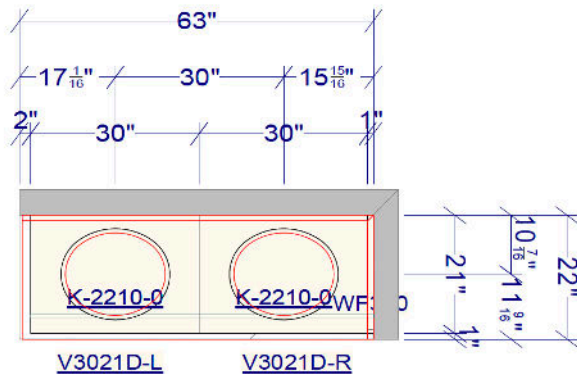

Master

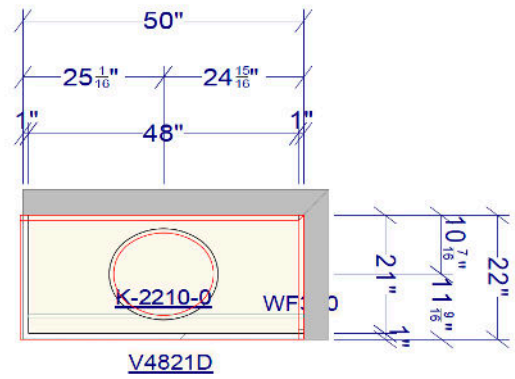

Guest

JSI Plymouth/Amesbury White Plywood Construction Soft Close
Doors Dovetail Full Ext Soft Close Drawers as Designed

Level One Granite Standard Edge and Backsplash with
White Oval Undermount Sinks