

The Will 2 (2,505 sq ft) – Front

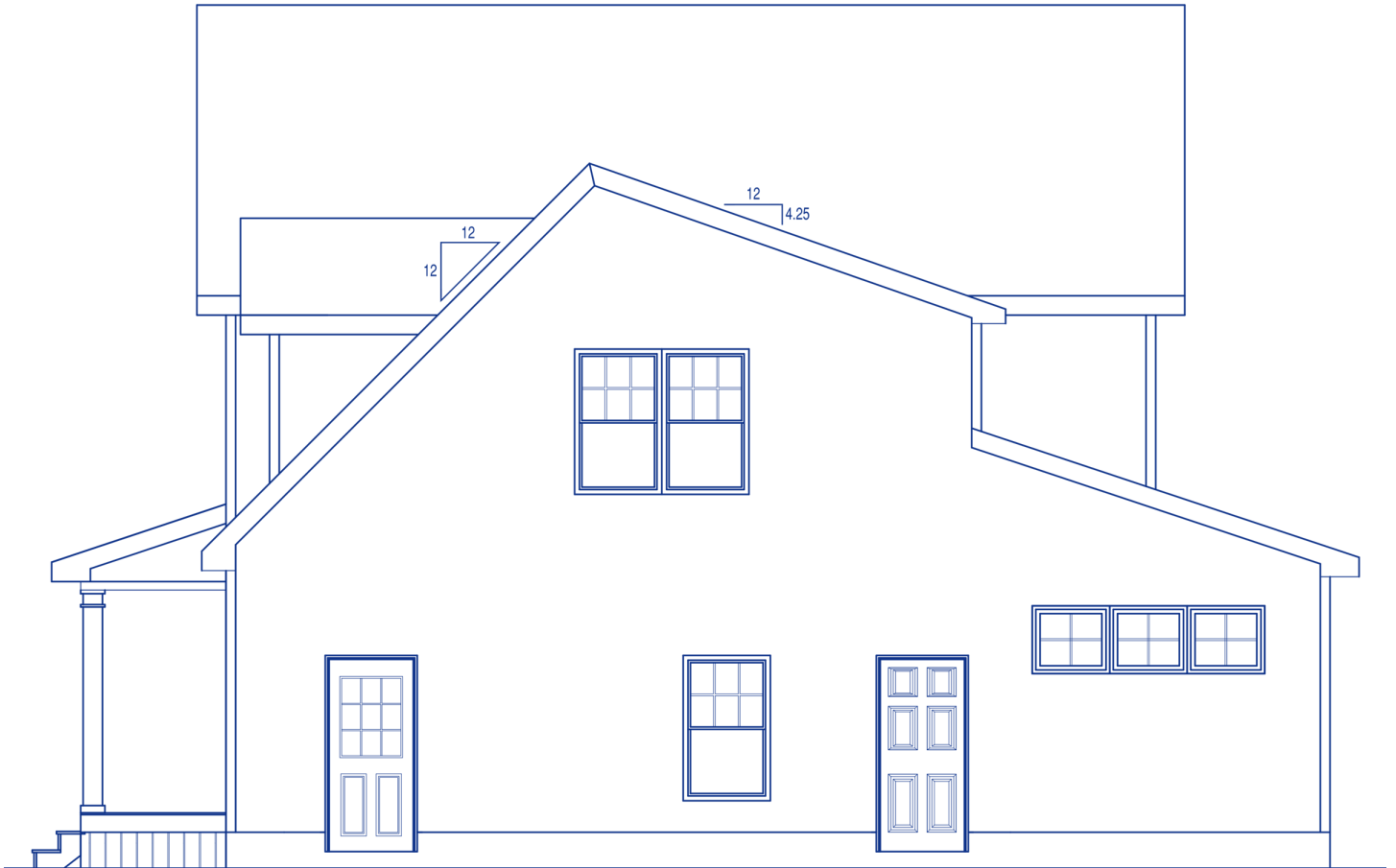

The Will 2 – Left



The Will 2 – First Floor Plan

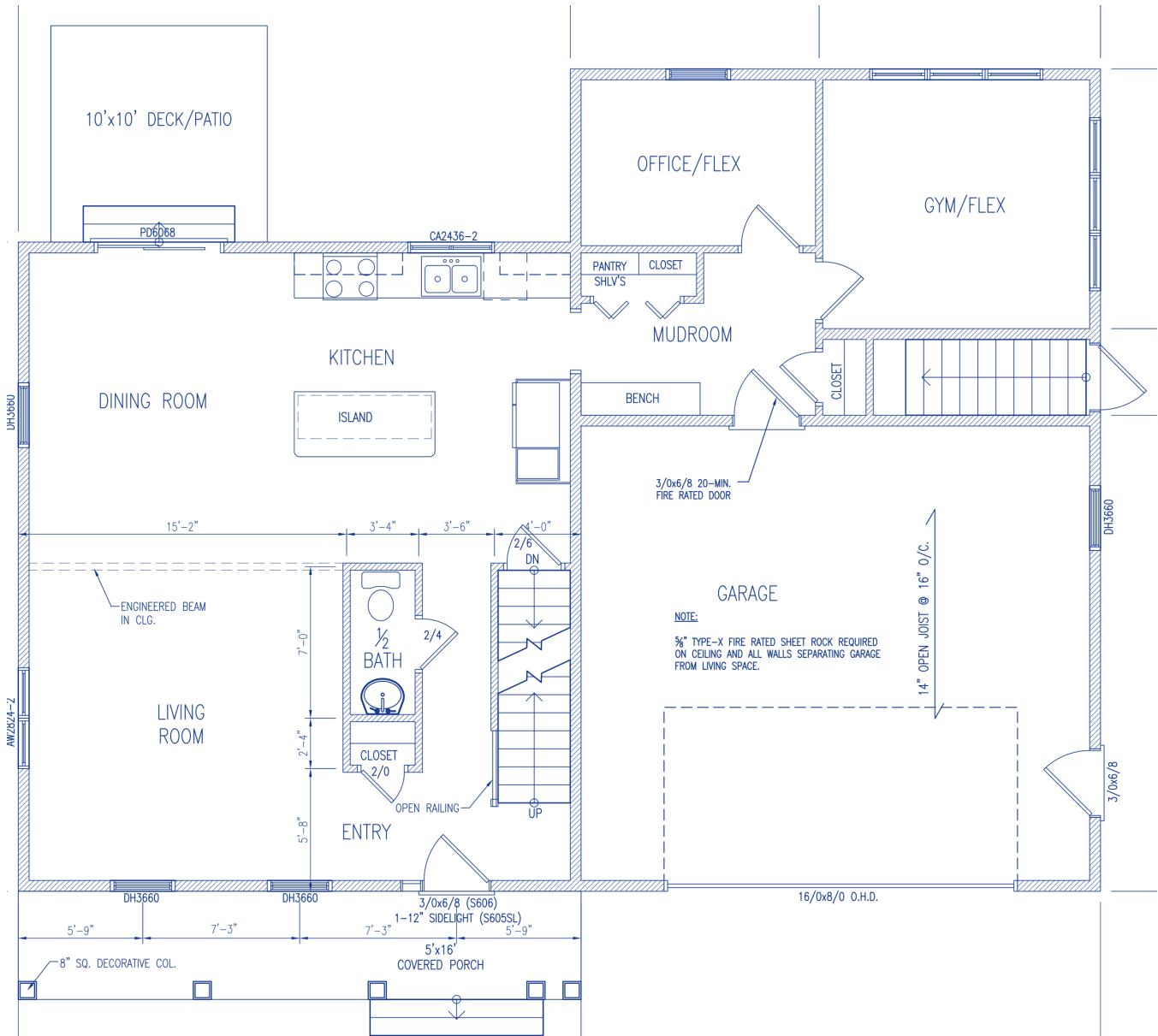

The Will 2 – Second Floor Plan

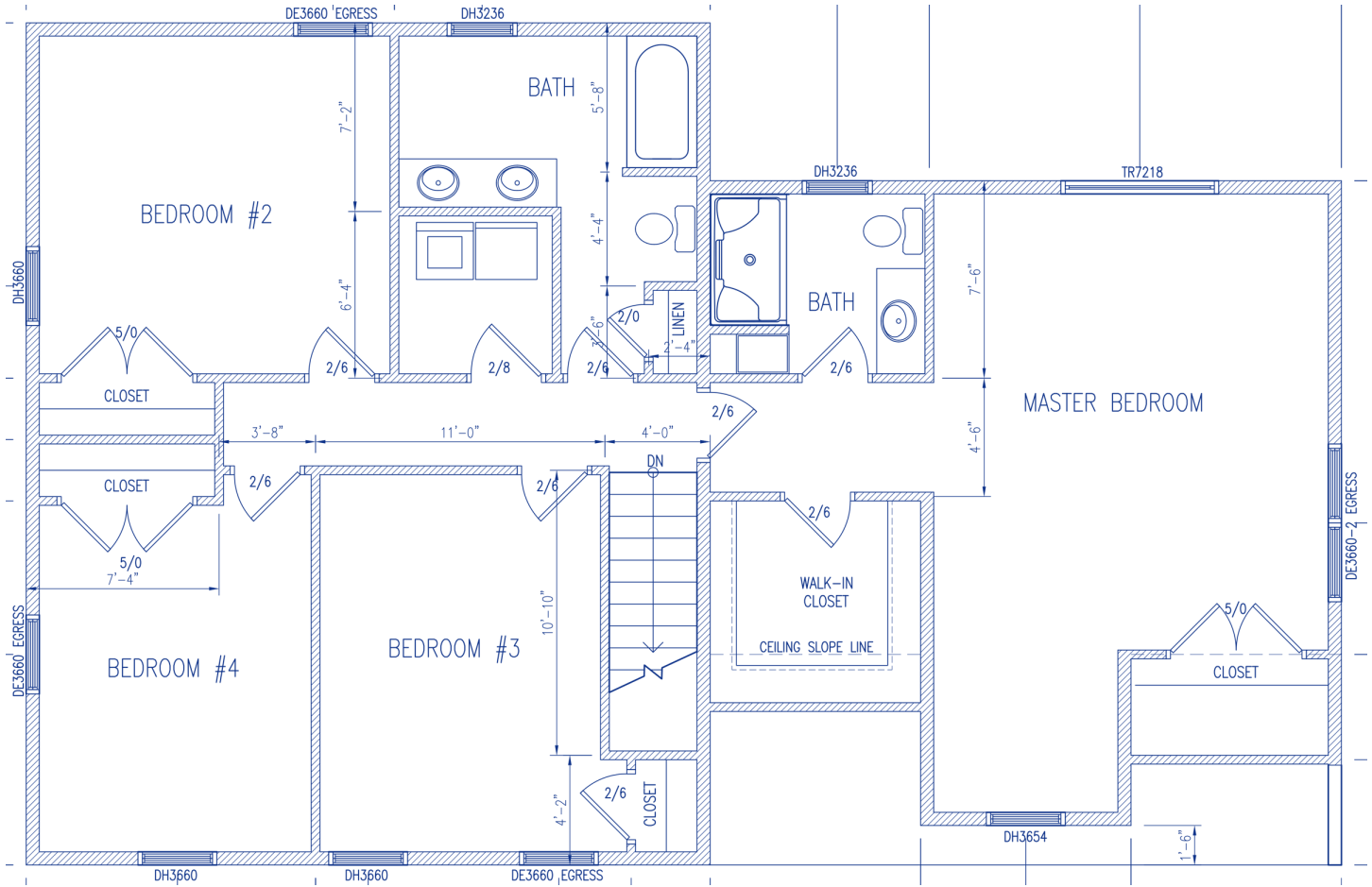

Kitchen Perspective 1



Kitchen Perspective 2



Vanities



Kitchen Plan

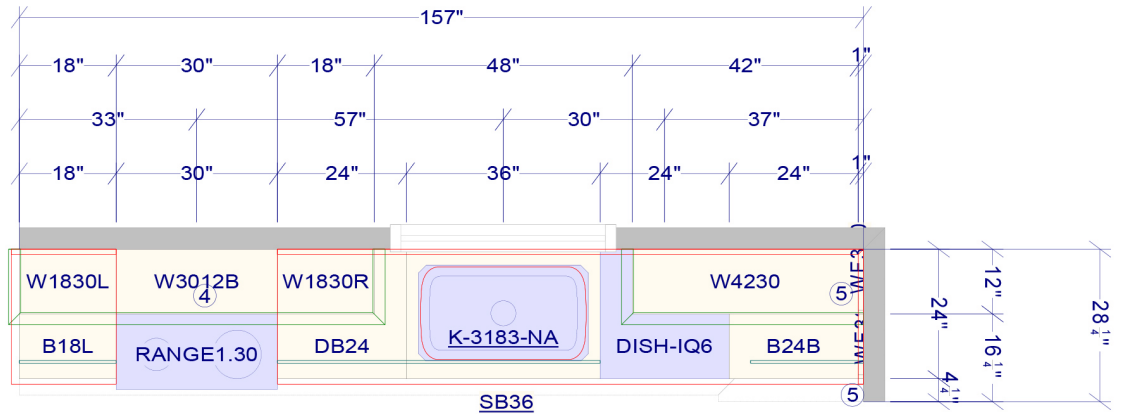

- 1-Fridge 36 x 72
- 2-24" Fridge Panel
- 4-Micro 30 x 15
- 5-Cut Filler to Fit on site
- 6-Panel
- 7-Outside Corner
- 8-Shoe

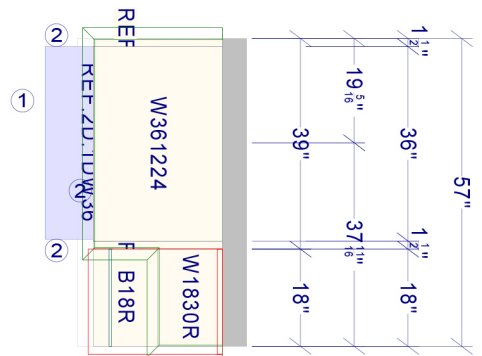
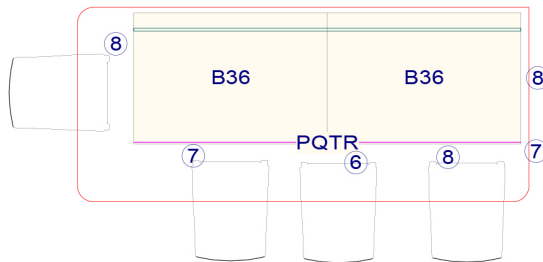

JSI Plymough/Amesbury White Plywood Construction, Soft Close Doors Dovetail Full Ext Soft Close Drawers, 30" Tall Wall Cabinets with Crown as Designed

Level One Granite Standard Edge and Backsplash with Large Undermount Stainless Steel Sink

Vanities Plan

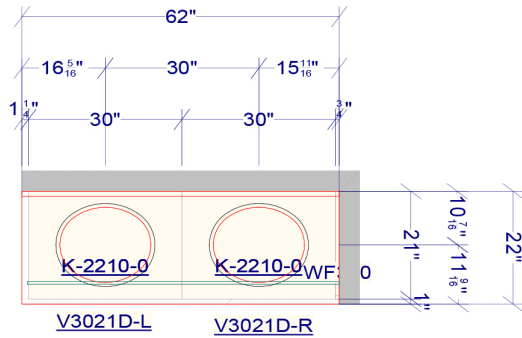

V3021D-L V3021D-R

Master

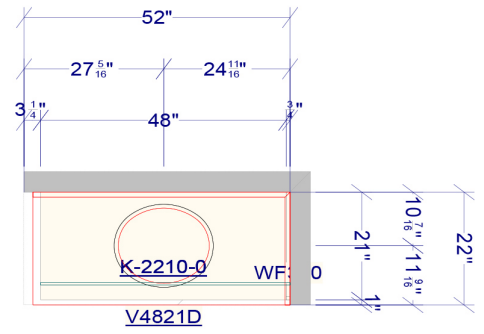

V4821D

Common

JSI Plymouth/Amesbury White Plywood Construction Dovetail Full Ext Soft Close Drawers as Designed

Vanity Level One Granite Standard Edge and Backsplash with White Undermount Oval Bowls